

AMATEUR TELEVISION HANDBOOK

VOL.2

TREVOR BROWN



BRITISH AMATEUR TELEVISION CLUB

9 HILLCREST,
TADLEY,
BASINGSTOKE,
HANTS,
RG26 6JB



WOOD & DOUGLAS

VHF/UHF COMMUNICATION PRODUCTS

JOIN THE

S. P. G. 'S (without your size '10'.....)

You could be a sync pulse generator with a W & D product. Our many years of experience in the commercial communication sector have benefited the amateur market with an extensive range of reliable well designed products. These are available in kit or assembled module form and a limited number as boxed ready to go units.

For your TV requirements whether AM or FM contact us. Full details of our complete range will be forwarded on receipt of a large SAE. We will also be very pleased to quote on any commercial enquiry be it for TV or telemetry. Please telephone for assistance.

Wood and Douglas are an independant British partnership who have served the UK amateur market for seven years. Why not support the

£ ?!

07356

5324

ACKNOWLEDGEMENTS

The British Amateur Television Club expresses its gratitude to the following companies, societies and individuals who have provided material and assistance for this publication.

R.S.G.B. Doughty Street, London.
R.S.G.B. Microwave Committee
Radio Ret. Paris.
A.G.A.F. Germany.
Wasco Electronics, Lancaster.

Mrs. Pauline M. Brown

Miss Catherine A. White

E. Balla VE2QC

C.G. Dixon G8CGK

C.C. Elliott G4MBS

A. Emerson G8PTE

F. Blakeborough G3PYE

G. Shirville G3VZV

EDITED BY TREVOR BROWN, G8CJS.

LAYOUT BY PETER DELANEY, G8KZG.

DRAUGHTED BY CHRIS SHARPE.

OCTOBER 1982

CONTENTS

<u>CHAPTER ONE</u>	<u>SLOW SCAN TELEVISION</u>	<u>PAGE</u>
	CHARACTER GENERATOR	1
	SYNC PULSE AND PATTERN GENERATOR	8
<u>CHAPTER TWO</u>	<u>TELETYPE</u>	
	PIGGY BACK MEMORY	11
	ASCII KEY BOARDS	19
	CHARACTER COLOURIZER	24
	SIMPLE SYNC PULSE GENERATOR	28
<u>CHAPTER THREE</u>	<u>VIDEO EFFECTS</u>	
	VISION SWITCHER	31
	VISION MIXING	38
	COLOUR SYNTHESIZER	45
<u>CHAPTER FOUR</u>	<u>70cms TELEVISION</u>	
	V.S.B. TRANSMITTER	53
<u>CHAPTER FIVE</u>	<u>MICROWAVE TELEVISION</u>	
	23cms FM TV TRANSMITTER	71
	23cms FM TV POWER AMPLIFIER	75
	23cms OMNI DIRECTIONAL AERIAL	77
	10Ghz TV TRANSCEIVER	84

PREFACE

In 1981 the British Amateur Television Club published "The Amateur Television Handbook". For the first time, a modular approach to building a television station was described, printed circuit boards were made available and a common card frame size was set for all the video projects.

Demand for "The Amateur Television Handbook" was so great that it was decided to go ahead with a Volume 2. This book does not replace the original Handbook, but it does supplement it and extend it.

The system of making printed circuit boards available for the major projects has been continued along with the standard I.S.E.P. card size for video projects. As was the case with "The Amateur Television Handbook", almost all the projects have been designed especially for this book, many of the projects having been requested by the readers of the original Handbook. The piggy back memory and character colouriser being prime examples, along with the 70cms V.S.B. transmitter.

This book is designed to start where the original Handbook finished and encompass Slow Scan Television and a more detailed look at the RF side of things.

The microwave bands have also been covered, in as simple a way as possible - in particular a video transceiver for the 10GHz band that uses a commercially available Gunnplexer for the front end.

The British Amateur Television Club is proud to present Amateur Television Volume 2.

Any correspondence concerning this book may be sent to:

Technical:-	Mr. T. Brown, 25 Gainsbro Drive, Adel, Leeds LS16 7PF
Printed circuit boards:-	Mr. P. Delaney, 6 East View Close, Wargrave, Berks. RG10 8BJ
Club Membership:-	Mr. B. Summers, 13 Church Street, Gainsborough, Lincs.

Please enclose an S.A.E. with all correspondence.

SLOW SCAN TELEVISION

CHAPTER 1

By Trevor Brown G8CJS.

Slow Scan Television is a form of television originally devised by Copthorne MacDonald as a project at Kentucky University, the aim of which was to see what sort of television pictures could be transmitted through a normal audio communication channel. It has since been adopted by many amateurs on a world wide basis enabling them to see their contacts as well as hear them.

With SSTV the images are transmitted at a slow rate, and essentially a series of still pictures are transmitted so no movement is possible. In the future, with the advent of micro-processors and memory stores, it is quite possible that this difficulty may be partially overcome. At the moment however, it is still pictures and text which form the transmission material. One development that does seem to be taking off is the transmission of colour pictures. Three separate pictures are sent, one Red, one Green and one Blue. These three pictures are stored at the receiving end in large digital memories and then displayed simultaneously to produce a colour picture. At the moment memories are expensive, so not many SSTV stations are equipped for colour. It also takes in excess of seven seconds to send one SSTV picture; multiply this by three for colour and it becomes very time consuming. Future development will only improve things and the next few years will bring many improvements to SSTV.

SSTV originally was devised as an AM system, but it soon became apparent that greater immunity to interference was obtained with an FM system and the parameters of the system now in use are shown in Table 1. It will be noted that the American 60Hz mains gives a longer duration for line and frame and pictures from these areas merely appear somewhat larger on the monitor screen, conversely they will see our pictures smaller than usual. The number of lines per picture was originally set at 120, but there is a growing tendency to use 128 as this division ratio can easily be obtained by binary dividers. Whatever picture is received, the line and frame amplitude controls should be adjusted to give 1:1 aspect ratio.

	50Hz Mains	60Hz Mains
Line Frequency	50÷3 ie 16.666Hz	60÷4 ie 15Hz
Duration of Lines	60ms	66.666ms
No. of lines in picture	128 ± 8	128 ± 8
Duration of picture	7.2 s. to 7.68 s	8 s to 8.533s
Line sync pulse	5 ms	5 ms
Frame sync pulse	30 ms	30 ms
Sync frequency	1200 Hz	1200 Hz
Black frequency	1500 Hz	1500 Hz
White frequency	2300 Hz	2300 Hz

Handbook One described a callsign generator that would work on either SSTV or fast scan television with only a few minor component changes required to change its operating standard.

The circuit was drawn with fast scan configuration and no FM modulator was shown for SSTV nor was an SSTV version PCB available. This chapter provides this information.

Later on in this book is a description of how to give the character generator keyboard access by adding a small piggyback module to the main PCB and all these modifications hold good for SSTV as well as fast scan.

Fig.1 shows the circuit diagram of the logic required to generate the characters. It is built around a 2513 character generator chip. This chip has been around quite a few years now. In the early stages of its development, it required very complex power rails, but the modern one now requires only +5 volts.

The PCB is laid out for the modern one only, so if instead of letters from the generator you get large white blocks rather like cue dots, then suspect the 2513, it may be very old in manufacture.

Note that General Instruments have only ever made +5 volt versions.

The 2513 is driven by a master clock and numerous counters that set the size and format of the print. The format chosen is 16 characters, in two rows of eight.

The final data leaves the 2513 as a 5 bit parallel word to a 74151 data selector where it is converted to serial data representing

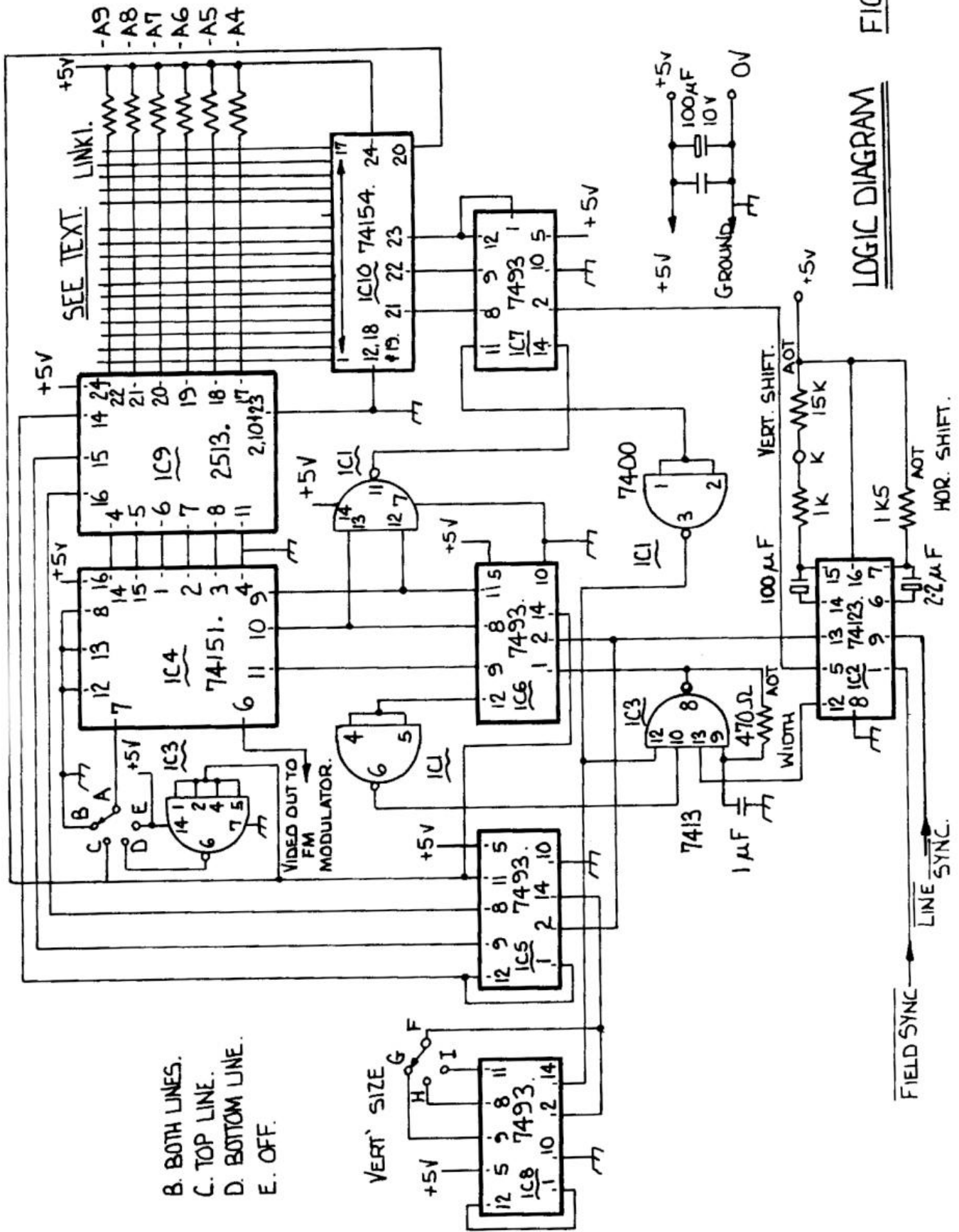

LOGIC DIAGRAM FIG.1.

the characters.

(See Handbook One for a detailed explanation of the Logic).

This digital signal now needs processing into the audio tones that make up an SSTV signal. Fig.2 shows how to do this.

The 741 is configured as an audio oscillator with the 4K7 resistor between Pins 6 and 3 providing the necessary positive feedback to make the stage oscillate. This configuration has very good stability. The oscillators frequency is independent of supply fluctuations.

The frequency is set by the 3K9 resistor, the 68nF capacitor and whichever capacitor is in parallel with the 68nF at the time, depending on which BC109 is switched on.

The logic is arranged so that inverted syncs are fed to the first BC109 so that it conducts during sync only. This causes the oscillator time constants to be 3K9, 68nF and 82nF which should make the oscillator frequency equal to 1200Hz.

The sync signal also disables the video path to stop any characters finding their way into the syncs.

The video logic is such that peak white is a Logic '0' and black a Logic '1'. During active picture the first BC109 switches off. If a Logic '1' is present on the video input, then the second BC109 will switch on making the oscillator time constants 3K9, 68nF and 47nF which should make the oscillator run at 1500Hz.

When characters are present, the video input will be at Logic '0'. This state means neither BC109 will be turned on resulting in a frequency set by 3K9 and 68nF which should be 2300Hz.

The output level is reduced to microphone level by the 47K and 470 ohm resistor while the 0.1 capacitor provides some degree of waveform shaping.

The input to the 2513 has provision for a diode matrix for hard wiring the Character Generator with your callsign etc. If you would like to use this instead of the keyboard add on, then you will need to refer to the programming chart. The symbol X denotes that a diode is required in that position in the matrix.

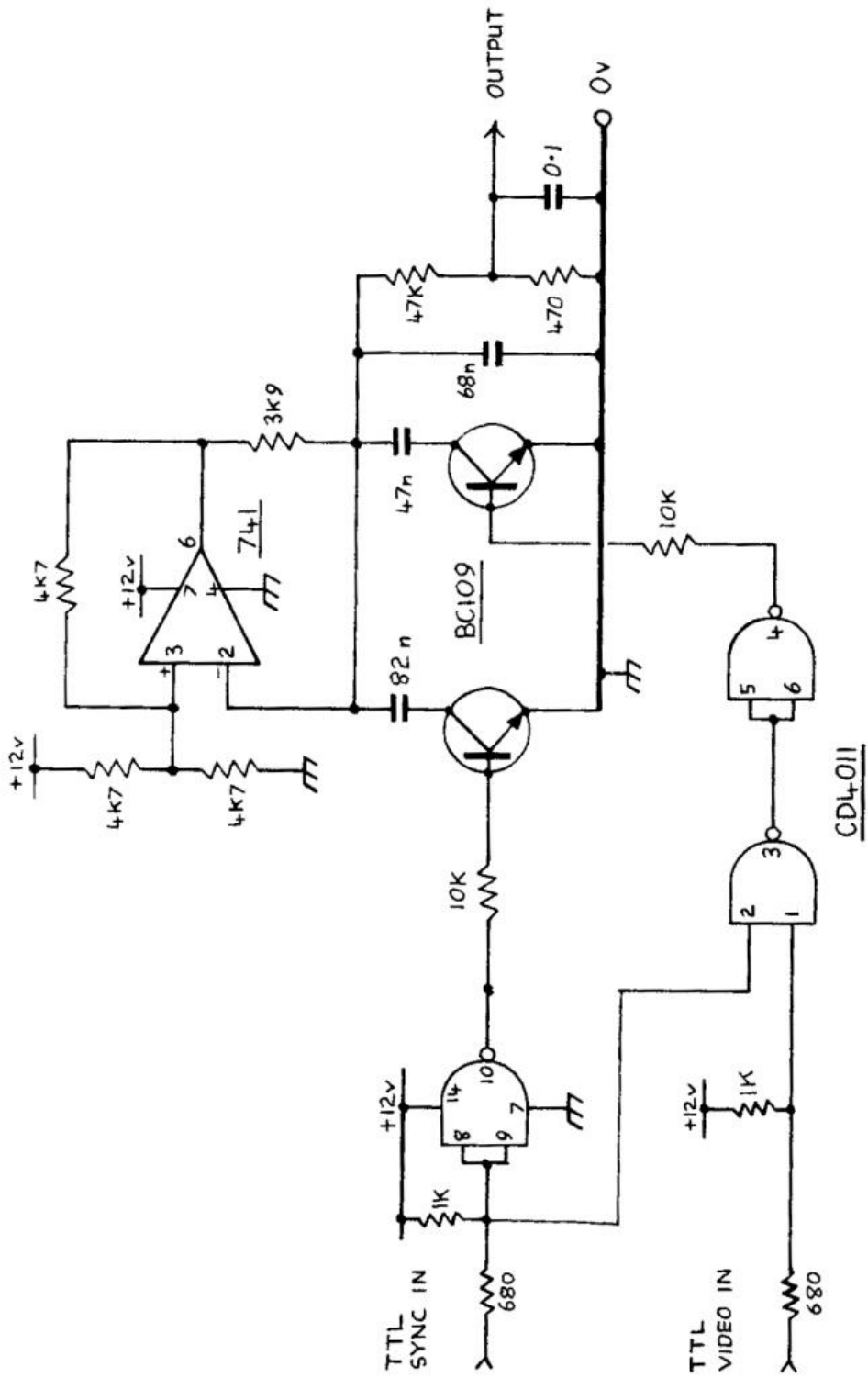

FIG. 2

PROGRAMMING

To choose each individual character a simple diode array is required which will connect the A4 to A9 inputs of IC9 to the binary-to-hexadecimal chip IC10. At the input of IC10 is a four bit code which changes every time a different character is output. The output of IC10 has 16 pins each of which goes low in turn as a different character is required.

The inputs of IC9 are pulled high by the 100K pull-up resistors so that the code input to IC9 with no diodes in circuit is 1 1 1 1 1 1 and produces the '?' symbol. A diode between an IC9 input and an IC10 output will cause one of the logic 1 states to be replaced by a logic 0.

If the printed circuit board matrix is being used, the inputs of IC9 are brought out to a six bit address bus which runs along the top of the printed circuit board. The outputs from IC10 are brought out on links, the link at the end of the address bus, i.e. that furthest from IC9, corresponds to the first letter.

The programme chart shows the placing of diodes to create any character in the case of 'G', for example, there is an 'X' in the first three columns, 'X' means that a diode is required so the A9, A8 and A7 inputs require diodes, whilst A6, A5 and A4 are left blank. The bus nearest the top edge of the printed circuit board is A9 and is represented by the first column in the programming chart.

The diodes are wired with the anode to the data bus and the cathode connected to the link corresponding to their position, i.e. if the first letter of the top line is the letter 'G', then diodes connect from A9, A8 and A7 to link 1.

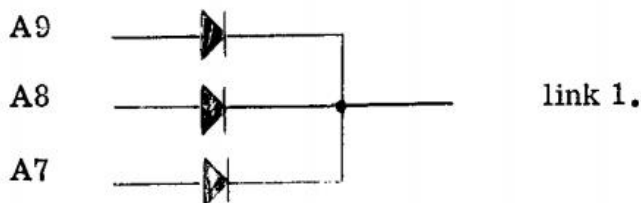

If the character required is a blank space, then five diodes are needed, this is a small problem when working with this kind of code, but it does represent a considerable economy in diodes over the earlier X-Y matrix type of character generators.

One final point on plug-in matrix boards. The ASCII address bus is already brought out to the edge connector because it is required to interconnect to the keyboard module so all that is required to remote the matrix (so that plug-in programme modules are possible) is that the programme links be wired to the edge connector. If you decide to do this, you should use pins 7 through to 11 and 22 through to 32 with the link nearest the edge connector going to pin 7. This will keep all modules compatible with each other and not cause any problems later when adding the keyboard module.

PROGRAMMING CHART

CHARACTER	A9	A8	A7	A6	A5	A4
A	X	X	X	X	X	
B	X	X	X	X		X
C	X	X	X	X		
D	X	X	X		X	X
E	X	X	X		X	
F	X	X	X			X
G	X	X	X			
H	X	X		X	X	X
I	X	X		X	X	
J	X	X		X		X
K	X	X		X		
L	X	X			X	X
M	X	X			X	
N	X	X				X
O	X	X				
P	X		X	X	X	X
Q	X		X	X	X	
R	X		X	X		X
S	X		X	X		
T	X		X		X	X
U	X		X		X	
V	X		X			X
W	X		X			
X	X			X	X	X
Y	X			X	X	
Z	X			X		X
BLANK		X	X	X	X	X
0			X	X	X	X
1			X	X	X	
2			X	X		X
3			X	X		
4			X		X	X
5			X		X	
6			X			X
7			X			
8				X	X	X
9				X	X	

'X' denotes that a diode is required.

SLOW SCAN SYNC PULSES

By Clifford Brownbridge G6BIN.

A good stable source of sync pulses is a prime requirement of any TV station whether it operates on slow or fast scan. In the early days the technique employed by slow scan pulse generators was to divide down from a mains locked source. The approach pioneered by G8CGK in which a 276KHz master oscillator was used to provide not only pulses, but 2300Hz, 1500Hz and 1200Hz frequency standards, was a major step in the right direction. This generator takes that technique one step further and increases the frequency of the master oscillator, and xtal locks it. This would normally escalate the number of counters required. Use of the larger Cmos counters can keep the chip count down to a reasonable proportion. The CD4040 12 bit counter being ideal. The use of a programmable read only memory to decode all the necessary counts also leads to reductions in logic while at the same time enabling two test waveforms to be generated. These two waveforms are grey-scale and chequer-board. They are both generated directly as FM signals so as to be independent of the oscillator unit (Fig.2), thus providing very useful signals of guaranteed frequency accuracy.

The choice of master oscillator frequency was such that xtals should easily be available and at a reasonable price, without adding complications to circuit design. The Eprom requires its address counter clocking every 15 micro seconds, if this is multiplied by 64, the result is the frequency of PAL Subcarrier i.e. 4.43MHz. As every colour TV set in the UK employs a xtal of this frequency, then they are bound to be cheap and plentiful for many years to come. To people in non PAL countries, sorry, but 3.5795 just does not work out the same.

Dividing by 64 is a very easy exercise for a binary stage counter, i.e. using its QF to reset the counter.

The line period of slow scan (60ms) is split into 4096 time domains, this number being the number of addresses in a 2732 EPROM. This makes each time domain 15 micro seconds approx. A way of generating this repetition rate was sought and proved to be PAL SUB CARRIER divided by 64, approx.

The 8 O/PS from the EPROM are all independently programmed.

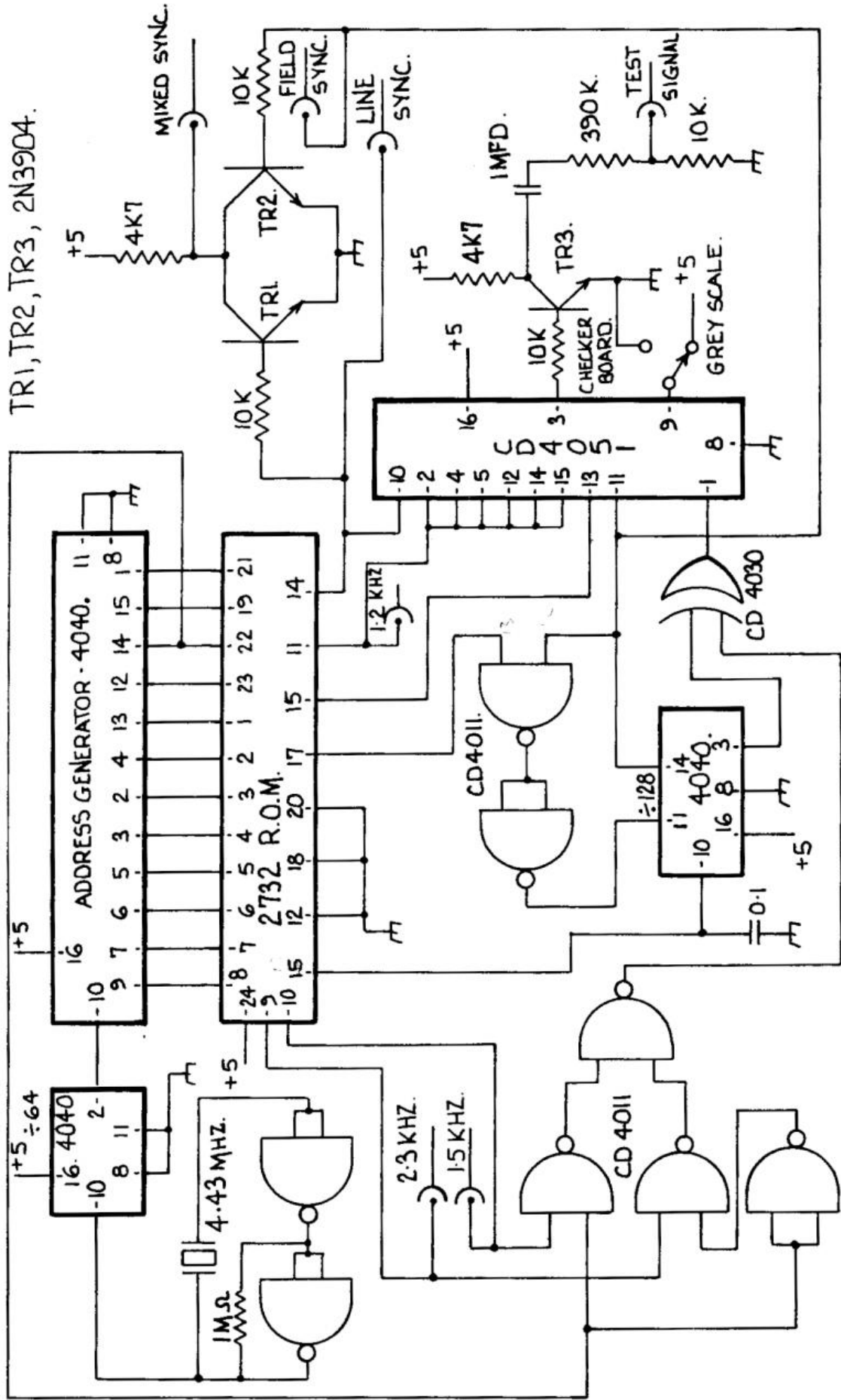

TR1, TR2, TR3, 2N3904.

SLOW SCAN S.P.G. AND TEST PATTERN GENERATOR.

FIG 3.

Three of them generate white, Black and sync frequencies directly with slight liberties being taken to synchronize with start of line timing. A fourth output gives a grey scale which is 8 different frequencies in the range 2.3KHz to 1.5KHz for 1/8 of line period each, approx. A fifth output gives a pulse 5 milli seconds in length at the start of line, i.e. line sync. A sixth output gives a short pulse to step on the line counter. A seventh output gives a 30 milli second neg. pulse to reset any other external circuitry (not used). The eighth output is timed to occur $\frac{1}{2}$ way through line so when the line counter reaches 128 it O/PS a frame pulse which is reset $\frac{1}{2}$ line later, i.e. 30 milli seconds.

By picking up two of the counter inputs, a chequer-board signal can be produced using the exclusive OR chip.

All these signals are then applied to the CD4051 DATA SELECTOR to generate composite grey-scale or chequer-board. This signal can go direct to the microphone input of the transmitter, or cassette recorder.

The line and field sync waveforms are such that they assume logic 1 during sync. They are both inverted and added together in TR1 and TR2 to provide mixed sync which is active low or logic 0 during sync. This signal can then be processed directly by the FM modulator section of the character generator (Fig.2).

It is always good S.S.T.V. practice to pass all signals through a band pass filter prior to transmission, Fig.4 shows such a circuit using operational amplifiers the gain is unity.

Remember, the 2732 is a pre-programmed chip and must be bought with the appropriate programme in it from B.A.T.C. Members Services.

FIG. 4

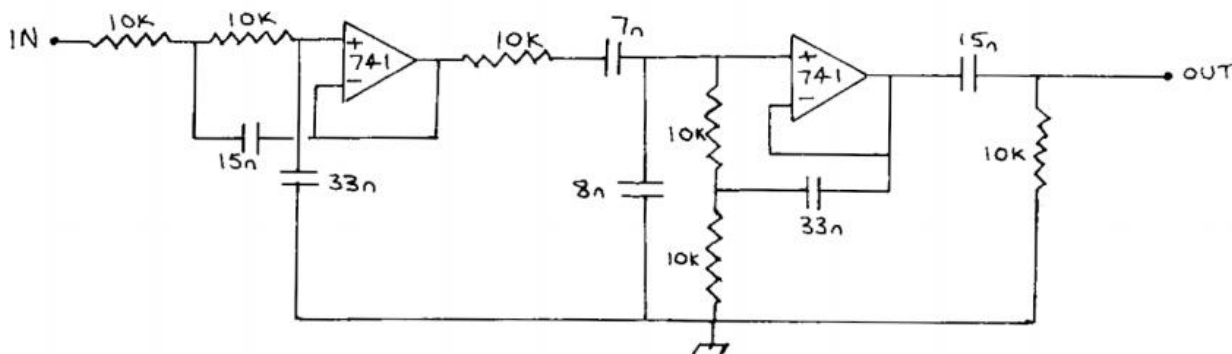

PIGGY BACK MEMORY

CHAPTER 2

By Trevor Brown G8CJS.

This is a new memory design using different techniques and more readily available memory chips. This new design also allows keyboard access to the Character Generator.

Instead of using an eight bit memory, two four bit memories, in the form of 2114's, which are at the moment inexpensive and plentiful, are used.

Another decision made was to keep this new circuit as simple as possible so as to be able to make the completed PCB small enough to fit piggy back style over the redundant diode matrix and space that was previously occupied by the 74154 diode matrix driver.

The new design is a very small versatile and inexpensive module, which met all requirements, with the only disadvantage being no visual cursor display and not being able to respond to ASCII commands other than straight forward printing of letters, numbers and symbols, i.e. back space and carriage return etc. The lack of cursor was not found to be much of an operational problem.

Cursor home can be provided by an external push button. Back space can also be provided by an external push button, although this command input to the module will require an external de-bounce circuit (see Fig.5). If either of these commands are not required, their inputs can be left floating.

The keyboard module operates as follows:-

Every time a key is pressed on the keyboard, the data lines of the keyboard output a code similar to setting up the toggle switches on the old memory unit. Also outputted from the keyboard is a strobe pulse. This strobe pulse switches on the 74367 buffer which connects the keyboard to the character data bus. The strobe pulse also switches to memory address lines away from the read clocks to the write address, i.e. the screen location to be typed into. The strobe pulse also puts the memory into a write mode, so the data on the data bus, which is the

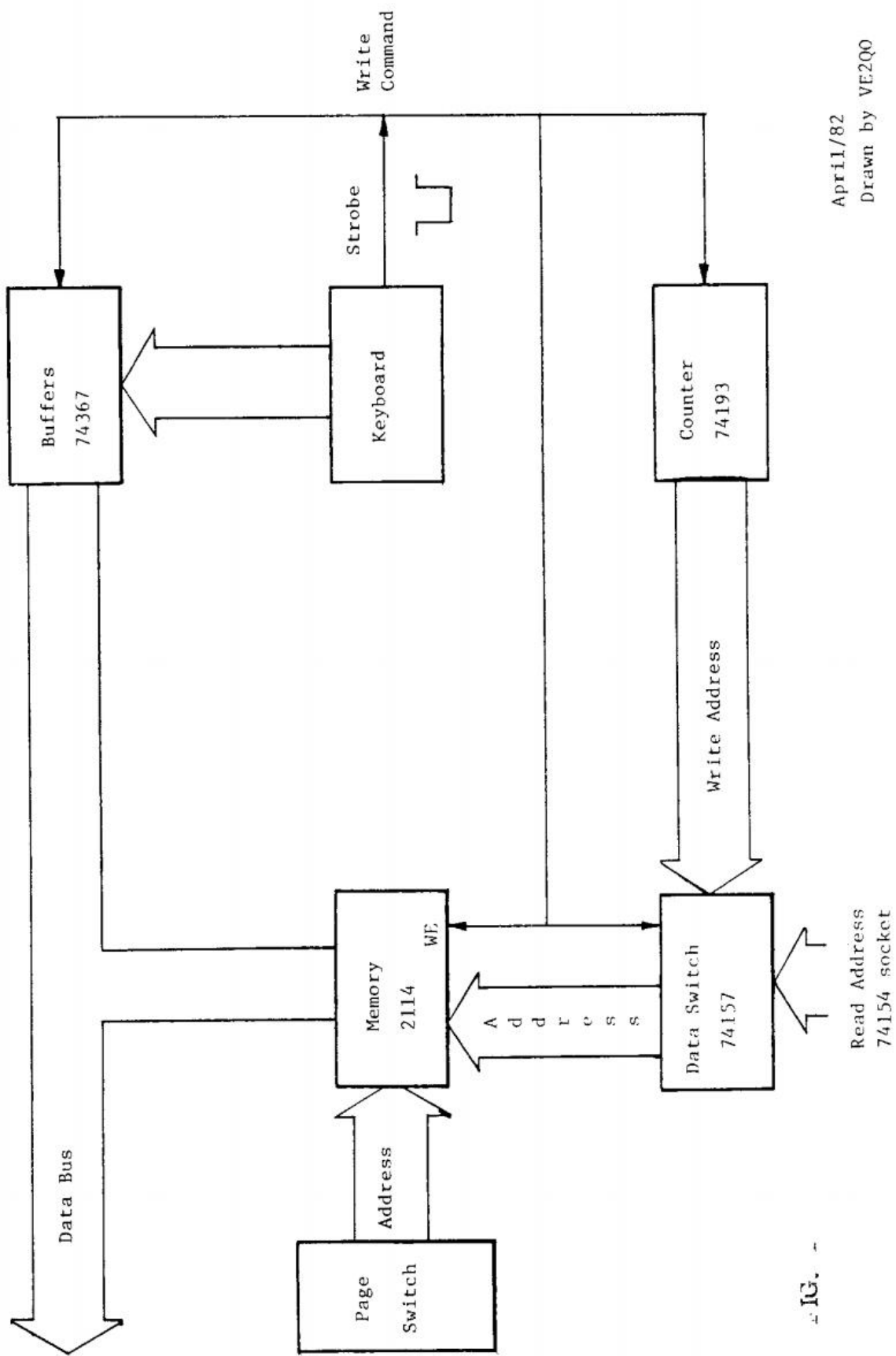

April/82
 Drawn by VE200

FIG. 1

keyboard data, is stored in that memory location. At the end of the strobe pulse, the memory is put back into a read mode and the 74157 switches its address lines back to the character generator read clocks. The 74367 takes the keyboard off the data bus and the 74193 is advanced so the next letter will be typed into the next location. The 74193 is a 16 bit counter, so it will automatically reset after the 16th character and the keyboard will overtype the letter in the first location.

Three of the spare memory address lines are brought out to provide a page switch. If this is required, they should be connected to outputs 1, 2 and 4 of a decade switch with the common connection being grounded. Provision is not made on the printed circuit board for the 3 x 100K pull up resistors, these should be mounted on the decade switch. If page facility is not required, connect these three lines to ground.

The system of switching to the write address during strobe pulse is a little unusual, but it does give almost instant keyboard access to the memory, which is essential if the character generator is used for SSTV.

It is still possible to use toggle switches instead of a keyboard with this unit. The strobe will have to be replaced with a load push button and de-bounce chip as per Fig.5, but the data on the switches will not be displayed prior to loading, as was the case with the old memory board.

The circuit and layout for the character generator are included for completeness.

CONSTRUCTION.

Mount all the integrated circuits as per the layout diagram taking care to insert the integrated circuits the correct way round. Next fit all the links using 24swg tinned copper wire and finally add the 180ohm resistor and the 10uF decoupling capacitor. Now decide if a page switch is wanted, if so, fit the lead out wires, if not, ground the connections. Wires to the cursor reset will also require adding at this stage - note one end of the cursor reset push button is connected directly to the 180ohm resistor. To connect the piggy back board to the character generator board, 24swg tinned copper wire is used. Initially, the connecting wires should be 12 inches long and connected to each of the dots as shown on the piggy back module layout diagram. Finally, inspect all the soldered joints and copper track on the underside of the piggy back printed circuit board. To this end a diagram of the print view of the printed circuit board is included. It is IMPOSSIBLE to rectify problems of this nature on the piggy back

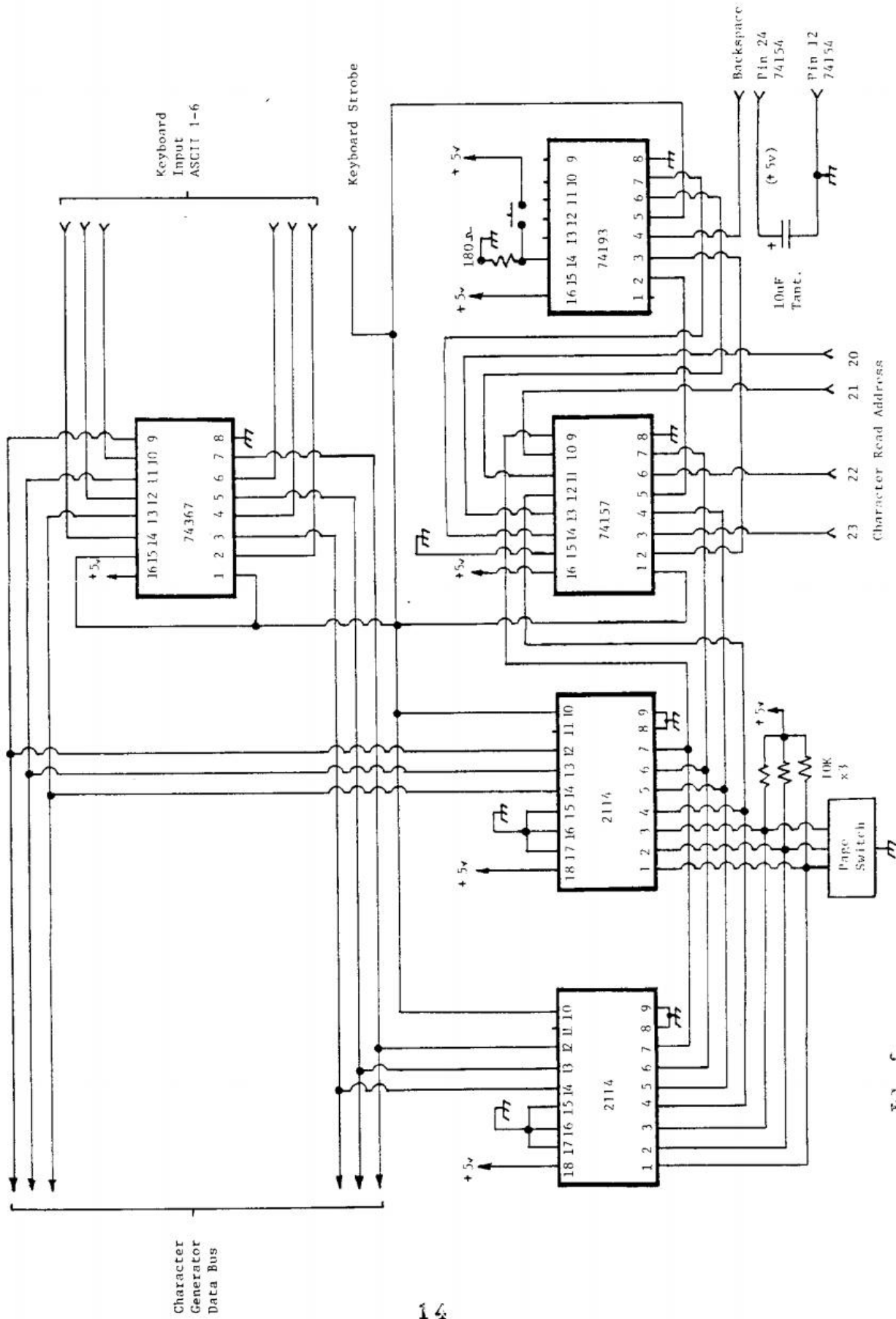

FIG. 2

Apr 11/82
 Drawn by VE200

board once it has been installed.

On the Character Generator, remove the 6 x 100K resistors from the data bus. Likewise any diodes in the matrix and the 74154 matrix driver chip. Clean out any of the holes that may have become blocked.

Starting at the end of the data bus nearest the 2513, feed the 3 wires from the module through the last three holes in the top three tracks of the data bus. Next connect the data outputs from the other memory chip, these go through the holes in the bottom three tracks of the data bus. Now feed the ground to the piggy module through to where Pin 12 of the 74157 used to go. Now feed the wires through what used to be Pins 20, 21, 22, 23 and 24 of the 74154, this is the read address and Vcc supply. Last go the connections either side of the 74367, these connections again go down to the data bus. Now the strobe and back space connection require connecting to edge Pins 7 and 8 of the Character Generator Board, this is done by feeding them through the holes that used to connect the transverse links in the diode matrix to Pins 2 and 3 of the 74154. Once these wires have been routed through the board to the underside, it is a simple job to sleeve them and connect them direct to edge Pins 7 and 8. Before soldering these interconnections between the two boards, it is important to get the module into its correct position, which is about half an inch above the Character Generator. Once this is done, solder all connections and cut off the surplus wire.

The data bus on the Character Generator Board now requires cutting between the connections that come down from either side of the 74367. This is indicated on the module component layout diagram. This operation is best carried out using a vico board cutting tool or small drill bit.

Pins 1 to 6 of the Character Generator now require connecting to the data lines of an ASCII keyboard, and Pin 7 to the keyboard strobe pulse. The keyboard should have a negative strobe pulse, such as the RCA VP 601 which is probably the most inexpensive keyboard available on the Amateur market. A table of connections for that particular keyboard is shown. Remember, the keyboard must be ASCII. Suggestions for keyboard alternatives appear later in this book.

The module can now be powered up and tested. As there are no upper case letters, the shift key must be operated when typing letters.

Included is an ASCII code table to help in sorting out keyboard connections should the generator fail to obey the keyboard correctly. It is a fairly simple task to press a few keys and cross reference the letter you type against the one that appeared on the screen and thus

Cut Data Bus
on Character Board
Here

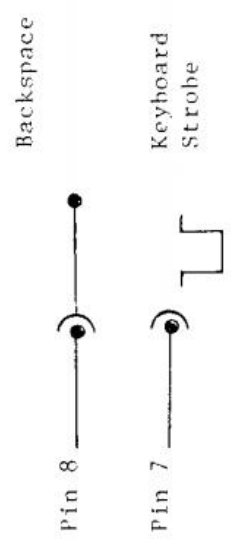
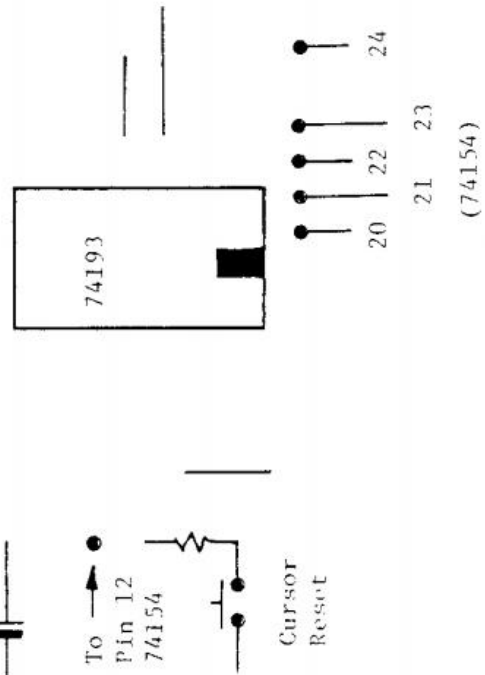
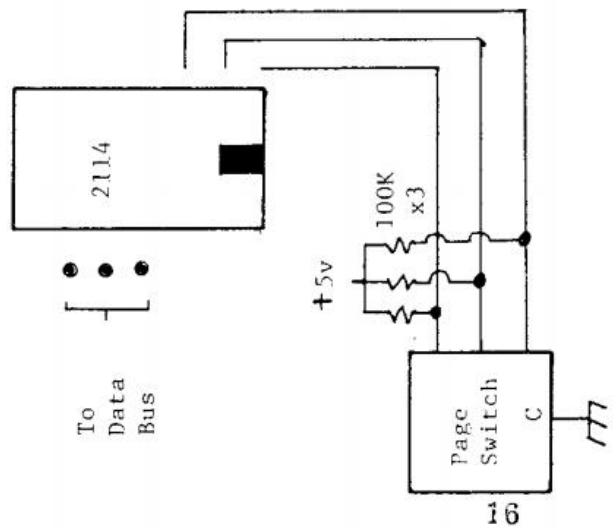
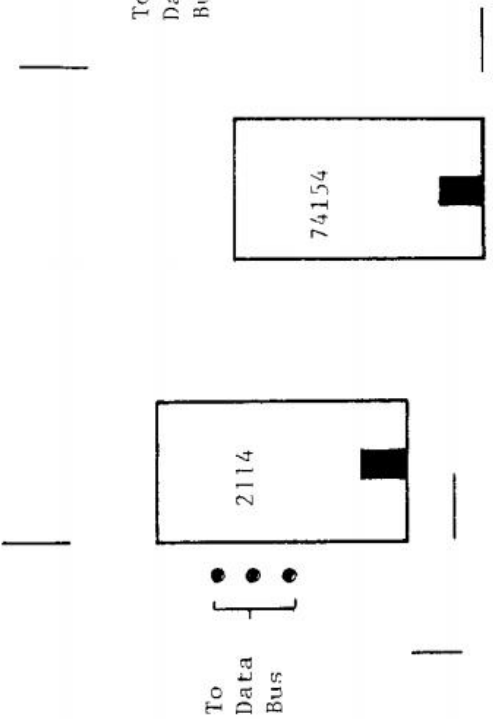
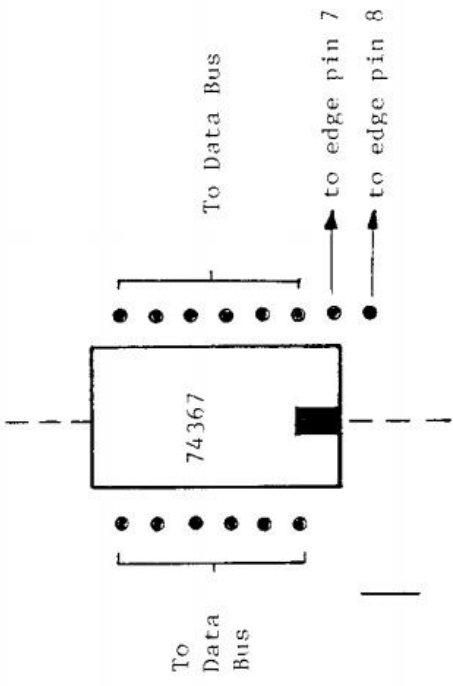

Pins 1-6 ASCII Data
from keyboard

FIG. 3

Keyboard Piggy Back Board - PC Layout

April/82
Drawn by VE200

screen and thus see where the data connections are transposed.

CHARACTER EDGE PIN	NOT USED	NOT USED	1	2	3	4	5	6	7

AY-5-2376	8	9	10	11	12	13	14	15	STROBE

VP601	13	15	17	19	20	18	16	14	10

ASCII	BIT 7	BIT 6	BIT 5	BIT 4	BIT 3	BIT 2	BIT 1	BIT 0	STROBE

@	0	1	0	0	0	0	0	0	0
A	0	1	0	0	0	0	0	0	1
B	0	1	0	0	0	0	0	1	0
C	0	1	0	0	0	0	0	1	1
D	0	1	0	0	0	0	1	0	0
E	0	1	0	0	0	0	1	0	1
F	0	1	0	0	0	0	1	1	0
G	0	1	0	0	0	0	1	1	1
H	0	1	0	0	0	1	0	0	0
I	0	1	0	0	0	1	0	0	1
J	0	1	0	0	0	1	0	1	0
K	0	1	0	0	0	1	0	1	1
L	0	1	0	0	0	1	1	0	0
M	0	1	0	0	0	1	1	0	1
N	0	1	0	0	0	1	1	1	0
O	0	1	0	0	0	1	1	1	1
P	0	1	0	1	0	0	0	0	0
Q	0	1	0	1	0	0	0	0	1
R	0	1	0	1	0	0	0	1	0
S	0	1	0	1	0	0	0	1	1
T	0	1	0	1	0	1	0	0	0
U	0	1	0	1	0	1	0	0	1
V	0	1	0	1	0	1	1	1	0
W	0	1	0	1	0	1	1	1	1
X	0	1	0	1	1	0	0	0	0
Y	0	1	0	1	1	0	0	0	1
Z	0	1	0	1	1	0	1	1	0
SPACE	0	0	1	0	0	0	0	0	0

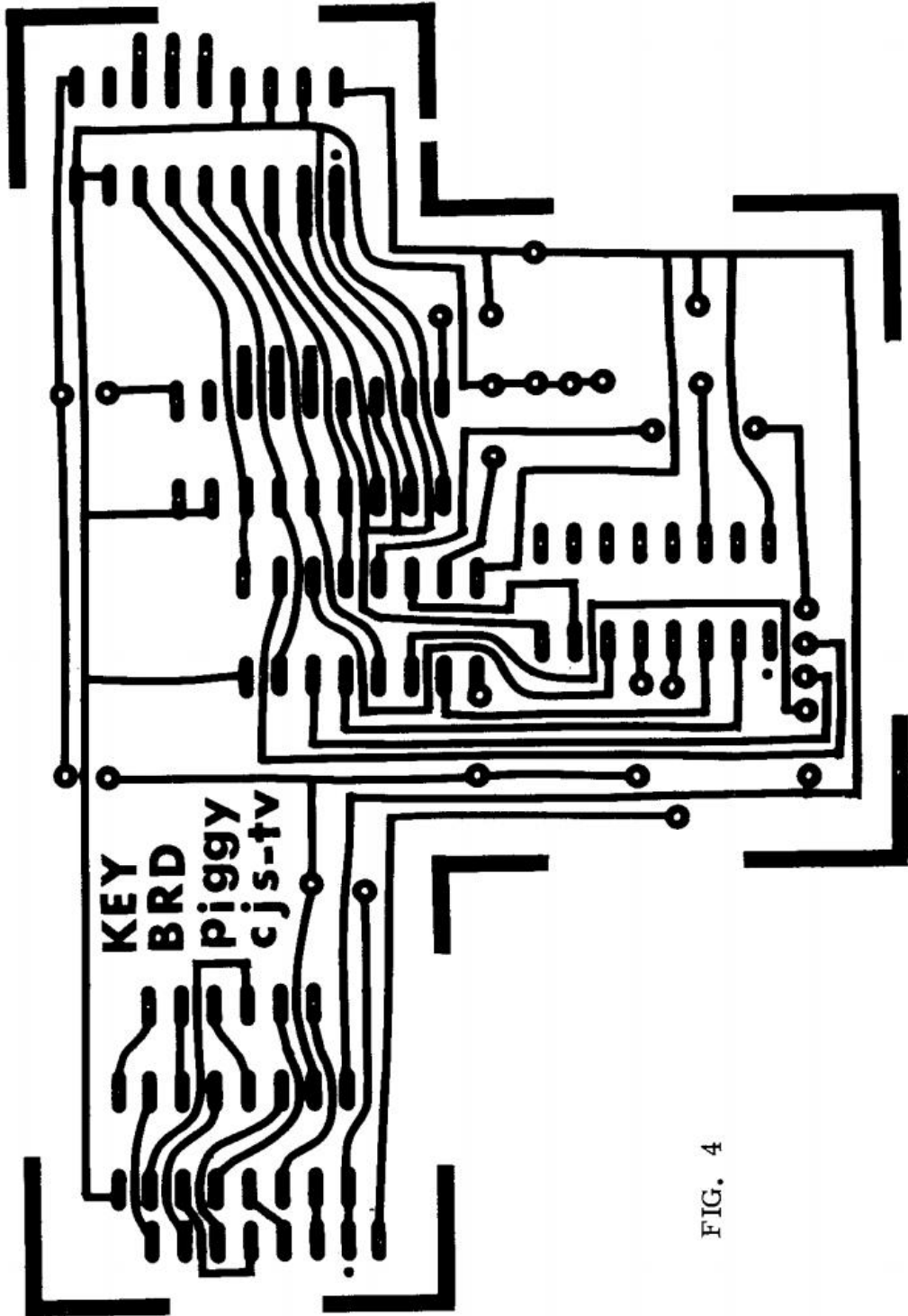

FIG. 4

A.S.C.I.I. KEYBOARD

By Trevor Brown G8CJS

There are several approaches to keyboards. The easiest solution is to buy one, find out its power requirements and then connect its data leads up to pins 1 - 6 of the Character Generator edge connector. The strobe may cause problems, as a negative going pulse is required, but most keyboards have both polarity strobe pulses available. Check the manufacturers data before purchase, above all making sure it is ASCII.

One way to avoid the problem is to use thumbwheel switches and separate load, back space and cursor home controls. Fig 5 shows how this can be done. The switches should be hexadecimal - they have 16 positions which are numbered 0,1,2,3,4,5,6,7,8,9,A,B,C,D,E,F. This is a strange way of counting, called Hex, and is worth remembering, as it often appears in logic, particularly with P.R.O.M.S. The look up table shows what number to set, to get each letter or number. The table is not complete, but half the fun is in finding out, trying all the numbers and seeing what appears.

If the thumbwheel idea does not appeal, then it is possible to construct an ASCII keyboard. There are two approaches to keyboard design. The first is a large diode matrix where pushing a button grounds the appropriate bus via diode gates. The other approach is where the data lines are constantly being clocked with all the combinations in the ASCII code. Depressing a key causes the code to stop when it reaches the corresponding code and a strobe pulse is then generated. Keyboards that use this system are called stroboscopic and are probably the easiest to build. The AY-5-2376 chip can make this task even easier as Fig 6 shows. 4 resistors, 2 capacitors and the push buttons make up the rest of the circuit. The push buttons should be of the push to make type, each one is used to make a connection between an X terminal and a Y terminal. The points where an X wire crosses a Y is one push button (see Fig 6). The strobe output requires a TTL gate to invert it, as only one polarity strobe is available from this chip. There is a way of inverting it but as this also inverts the data, is not a practical alternative.

The connections from the ASCII data outputs to the character generator edge connector are shown at the top of the ASCII table in the previous chapter.

The use of an AY-5-2376 'IC' as a keyboard encoder does

SIMPLE ASCII KEYBOARD

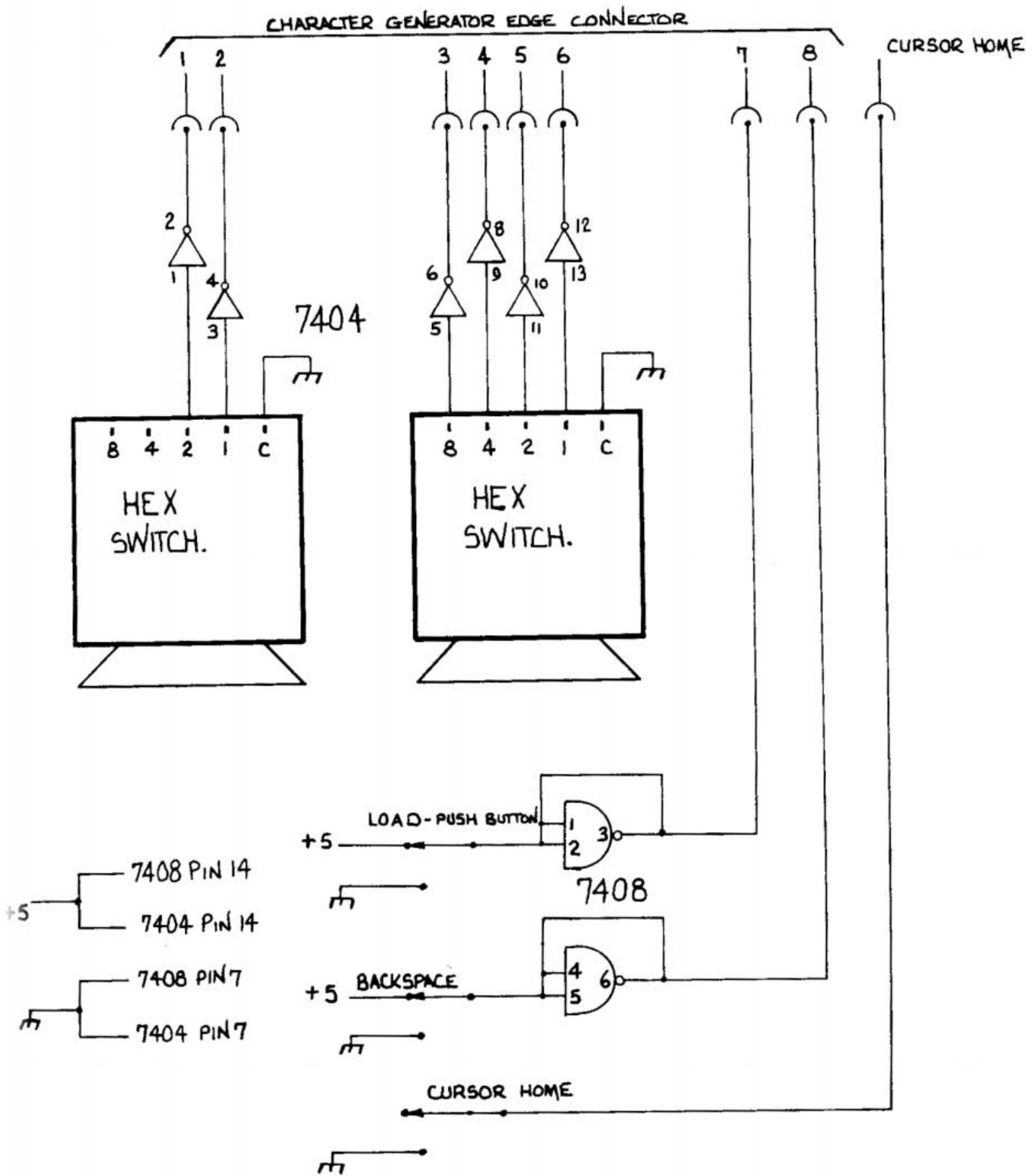

FIG. 5

ASCII KEY BOARD

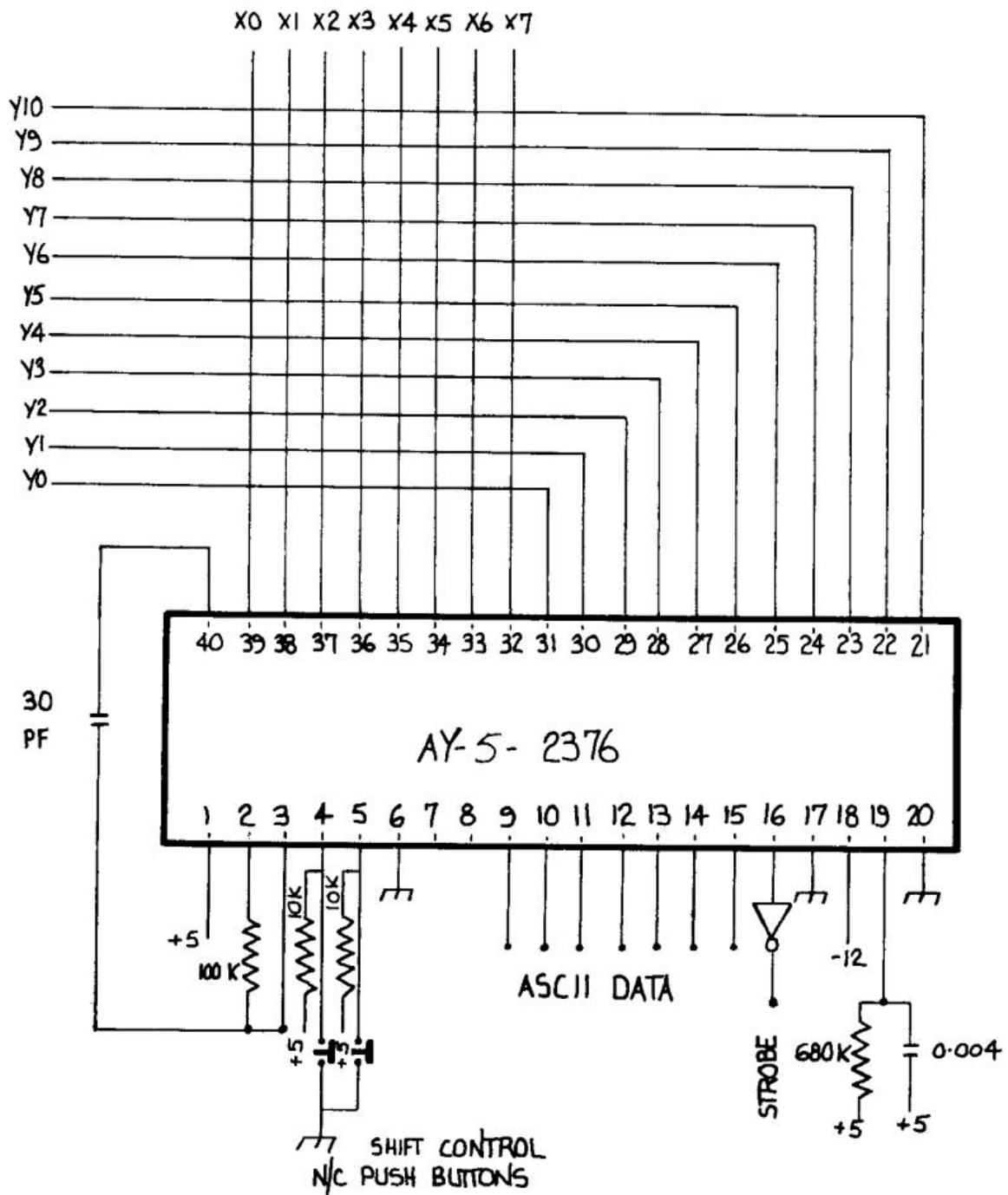
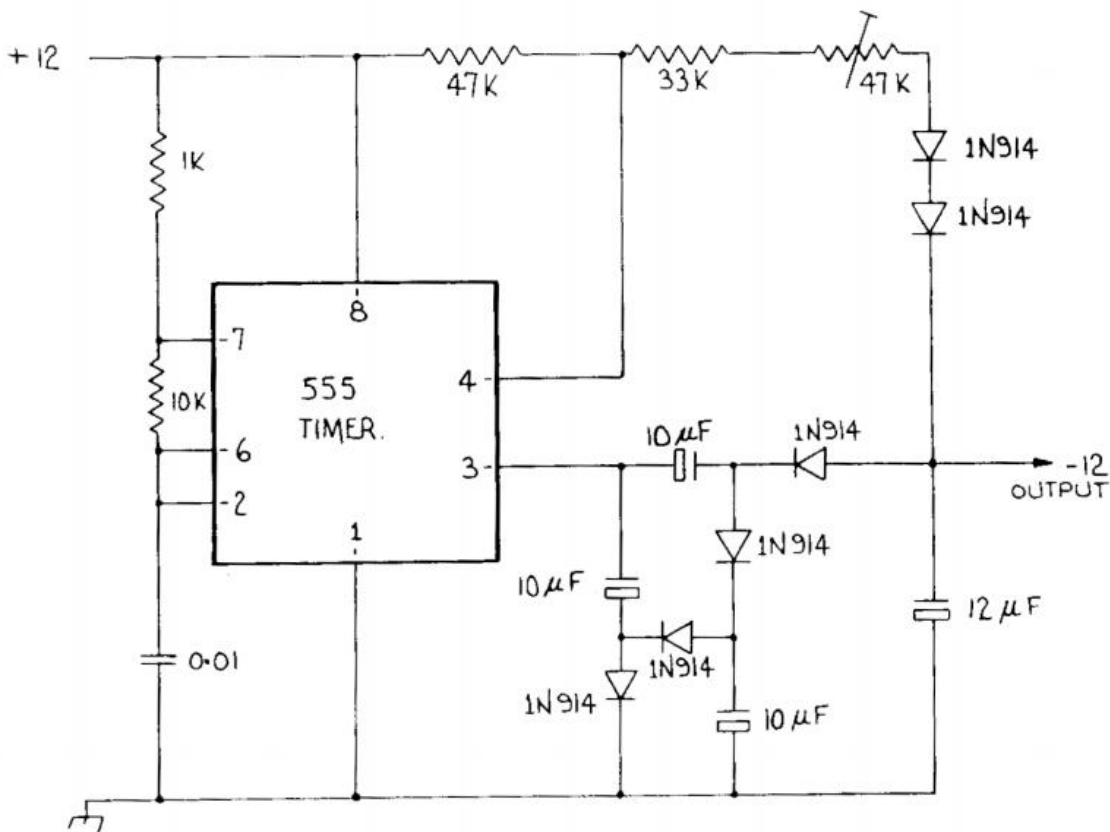

FIG. 6.

introduce the problem of a negative power rail, which could be a problem in a portable situation. The consumption is very low on this particular rail, enabling the circuit below to be used to generate this -12 volt rail from a +12 supply.

The 555 timer is operated as a free running astable multi-vibrator operating in the 10KHz region. The resulting square wave output at pin 3 is rectified in a voltage doubler circuit to provide a negative power rail capable of supplying up to 30mA, with very good stability. Regulation is provided by the potential divider which feeds Pin 4. Should Pin 4 fall below 0.7 volt, i.e. the negative rail is too high, then the oscillator will stop, and the voltage across the 12uF reservoir capacitor will fall as it is discharged by the circuit load. When Pin 4 rises above 0.7 volt the oscillator will again run, and top up the 12uF reservoir capacitor. The 47K variable in the chain allows the operating point of Pin 4 to be adjusted and hence controls the output voltage. This pot should be set for -12 volts. The two series diodes in the potential divider loop are included to compensate for a base emitter junction within the 555 and thus provides temperature stability.



CHARACTER	HEX THUMBWHEEL	x TO y ON KEYBOARD	
@	40	x3 - y4	
A	41	x5 - y8	*
B	42	x4 - y6	*
C	43	x4 - y8	*
D	44	x5 - y6	*
E	45	x6 - y6	*
F	46	x5 - y5	*
G	47	x5 - y4	*
H	48	x5 - y3	*
I	49	x6 - y1	*
J	4A	x5 - y2	*
K	4B	x5 - y1	*
L	4C	x5 - y0	*
M	4D	x4 - y4	*
N	4E	x4 - y5	*
O	4F	x6 - y0	*
P	50	x3 - y2	*
Q	51	x6 - y8	*
R	52	x6 - y5	*
S	53	x5 - y7	*
T	54	x6 - y4	*
U	55	x6 - y2	*
V	56	x4 - y7	*
W	57	x6 - y7	*
X	58	x4 - y9	*
Y	59	x6 - y3	*
Z	5A	x4 -y10	*
0	30	x3 - y0	
1	31	x7 - y8	
2	32	x7 - y7	
3	33	x7 - y6	
4	34	x7 - y5	
5	35	x7 - y4	
6	36	x7 - y3	
7	37	x7 - y2	
8	38	x7 - y1	
9	39	x7 - y0	
\$	24	x7 - y5	*
%	25	x7 - y4	*
&	26	x7 - y3	*
?	3F	x4 - y1	*
(28	x7 - y1	*
)	29	x7 - y0	*
SPACE	20	x2 - y8	
BACKSPACE	08	x3 - y5	
RETURN	0D	x3 - y8	
ESCAPE	1B	x5 -y10	
LINE FEED	0A	x3 - y9	

*DENOTES SHIFT KEY SHOULD ALSO BE DEPRESSED

CHARACTER COLOURIZER

By Trevor Brown G8CJS.

The LM1889 TV Video Modulator has been around a while and it does have the ability to make coded P.A.L. or NTSC from colour difference signals. The LM1889 will also work with 4.4336MHz or 3.5795MHz subcarrier making it an ideal chip for providing a colour option for the Character Generator, or other digital vision sources.

The only problem left is to select how much R.G. or B is wanted on the screen at any one point. This is done by joining the three bits of each word input together, restricting us to 100% chroma. If a decade switch is used to drive the LM1886, it will give the following colours, dependent upon switch position.

- 0 - White
- 1 - Cyan
- 2 - Magenta
- 3 - Blue
- 4 - Yellow
- 5 - Green
- 6 - Red
- 7 - Black

A 74157 data selector switches between two such decade switches. This data selector is operated by character data so as to bring one decade switch on line during the characters and the other decade during background, thus giving separate control over the colour of the characters and background.

A further addition is to use the MSB of the background switch to switch another 74157 and bring on line a colour bar generator as a background. This corresponds to positions 8 and 9. The colour bar generator is made by using $\frac{1}{2}$ of a 7413 as a clock oscillator which is made line synchronous by stopping it oscillating during mixed blanking. This clock is used to advance a 74193 4 bit counter. The other half of the 7413 is used to detect when the counter is full and stop the clock. Line sync is used to reset the counter and start the cycle all over again. If the three most significant bits of this counter are used as green, red and blue, then 100% colour bars result. These colour bars will be inverted i.e. the blue bar is on the left.

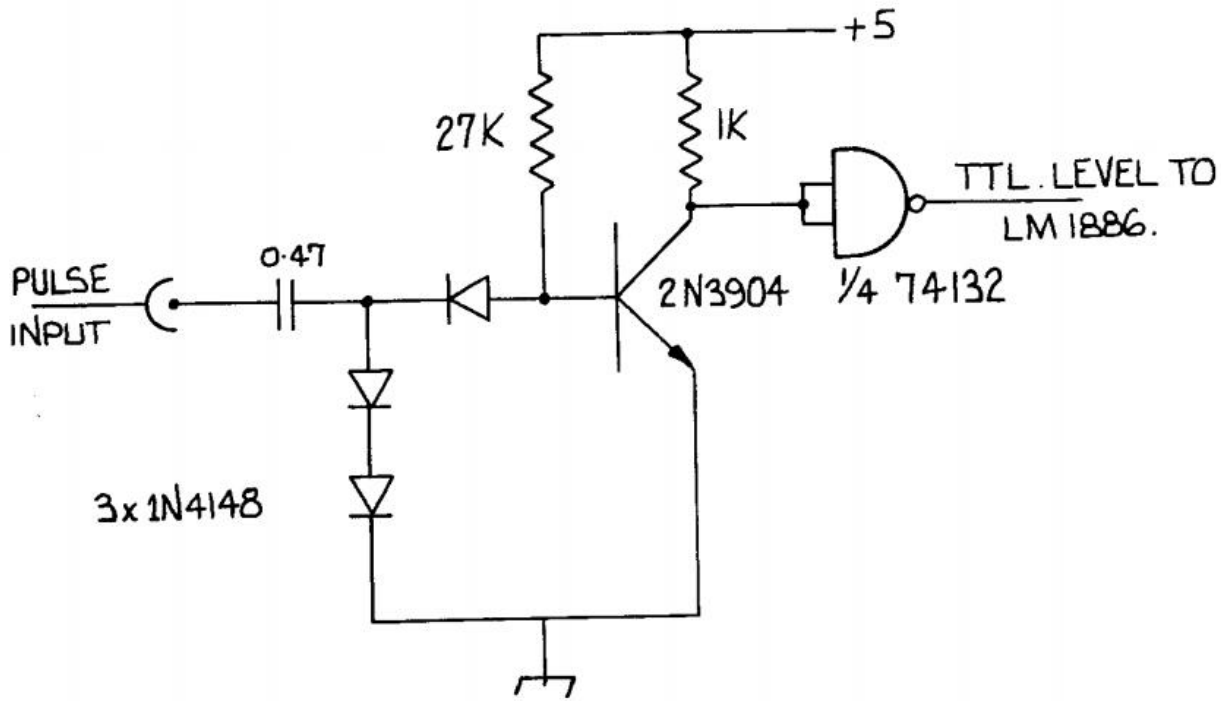

FIG. 2

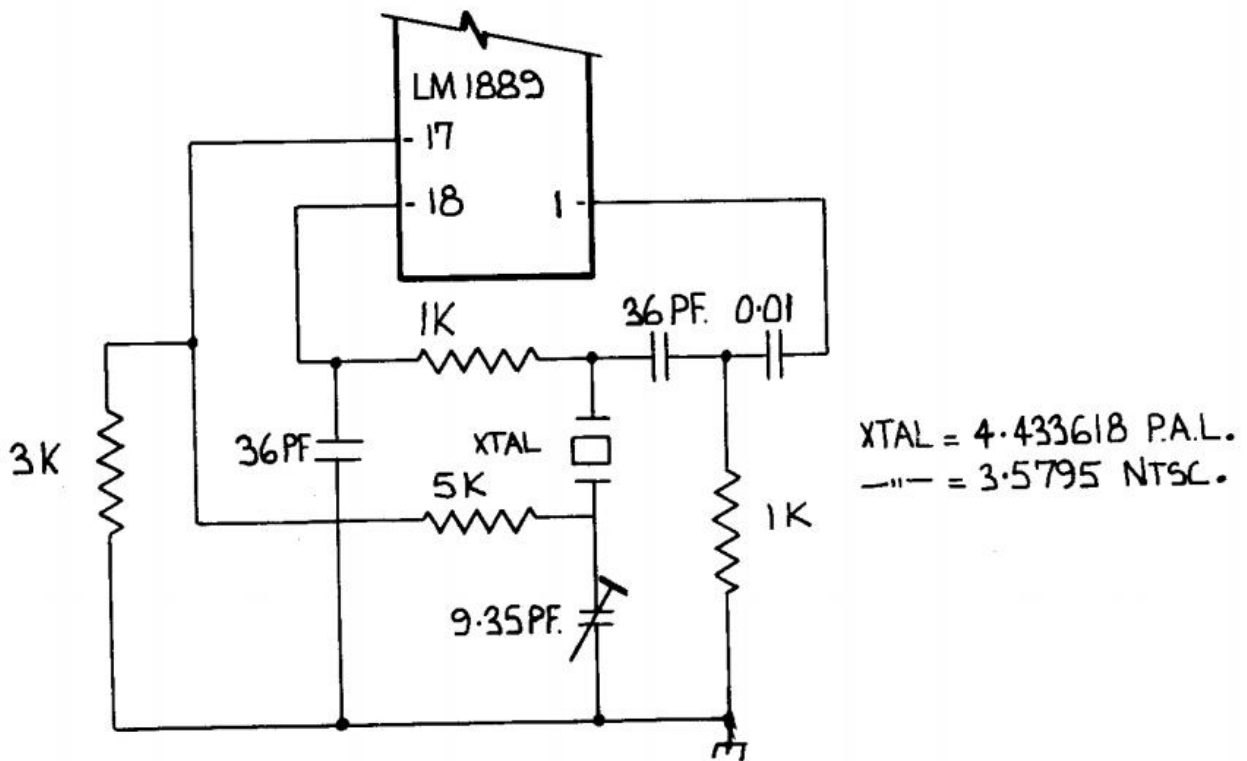

FIG. 3

This distinguishes them from the test bars available by making the test card in Handbook One. If they are to be the same as the test card colour bars, then replace the background 74157 with a 74158 they are pin compatible. If sockets are used when building the PCB, then the task of deciding which way round the colour bars are to be can be left until the end. If the colour bars finish before the end of line scan, then it is necessary to slow down the line locked oscillator. This is done by putting a small value capacitor in parallel with the 6800pF time constant on the input of the 7413 gate.

When the LM1889 is used with 3.5795MHz subcarrier, the two phase shift capacitors marked * require increasing in value to 43pF.

The mixed blanking, mixed sync, burst gate and P.A.L. switch inputs are all TTL level inputs and can be driven direct from the ZN134J and associated colour logic in Fig.4.

If a 2v pulse distribution system is preferred, then it will be necessary to add the pulse drive stages in Fig.2 to each pulse input.

The subcarrier input is designed to accept a level of one volt. In the absence of a subcarrier generator then it is possible to make the LM1889 generate its own subcarrier. Fig.3 shows how to do this.

A printed circuit board is available for this project. It is a card of ISEP rack standard as per the original character generator.

The printed circuit board is laid out along with the pulse drivers in Fig.2 so as to accept a 2v pulse distribution system and a feed of external subcarrier.



SYNC PULSE GENERATOR

BY JOHN LAWRENCE GW3UGA
AND DAVID JONES GW8FEA.

The generating of sync pulses with today's technology could not be easier. Ferranti do a range of logic called U.L.A. which stands for uncommitted logic arrays, - the idea being to produce a range of chips that can be tailor made to perform any logic function the customer desires. One of these devices is prewired as a monochrome sync generator.

This chip (ZN134J) requires an external xtal, the rest of the xtal oscillator is already in the chip. Also inside the chip is all the necessary counters and associated logic to generate Mixed Sync., Mixed Blanking, Field Drive and Line Drive. The outputs are all TTL level signals and the chip requires only a +5 volt power rail.

The ZN134J is capable of generating either 525 line or 625 line standards. The xtal requires changing and pin 2 requires +5 volts for 625 lines and ground for 525 line standards.

The only problem with the ZN134J is that it does not have the necessary additional logic for colour work. This means that it has no burst gate or PAL switch outputs available.

By making a few compromises in the colour system, we can produce these two missing signals, perhaps not to broadcast standards, but to a standard that produces excellent colour results, indistinguishable from broadcast colour when viewed on a normal colour monitor.

The line drive output on Pin 5 of the ZN134J is used to clock a D type flip flop that has its D input connected to its \bar{Q} output, thus forming a divided by 2 counter. The output of this D type can be used as PAL switch.

The line drive waveform can be used to trigger off a pair of cascaded monostables, the output of the second being the burst gate. The first monostable is used to position the burst correctly. The 6K8

SIMPLE DUAL STANDARD S.P.G.

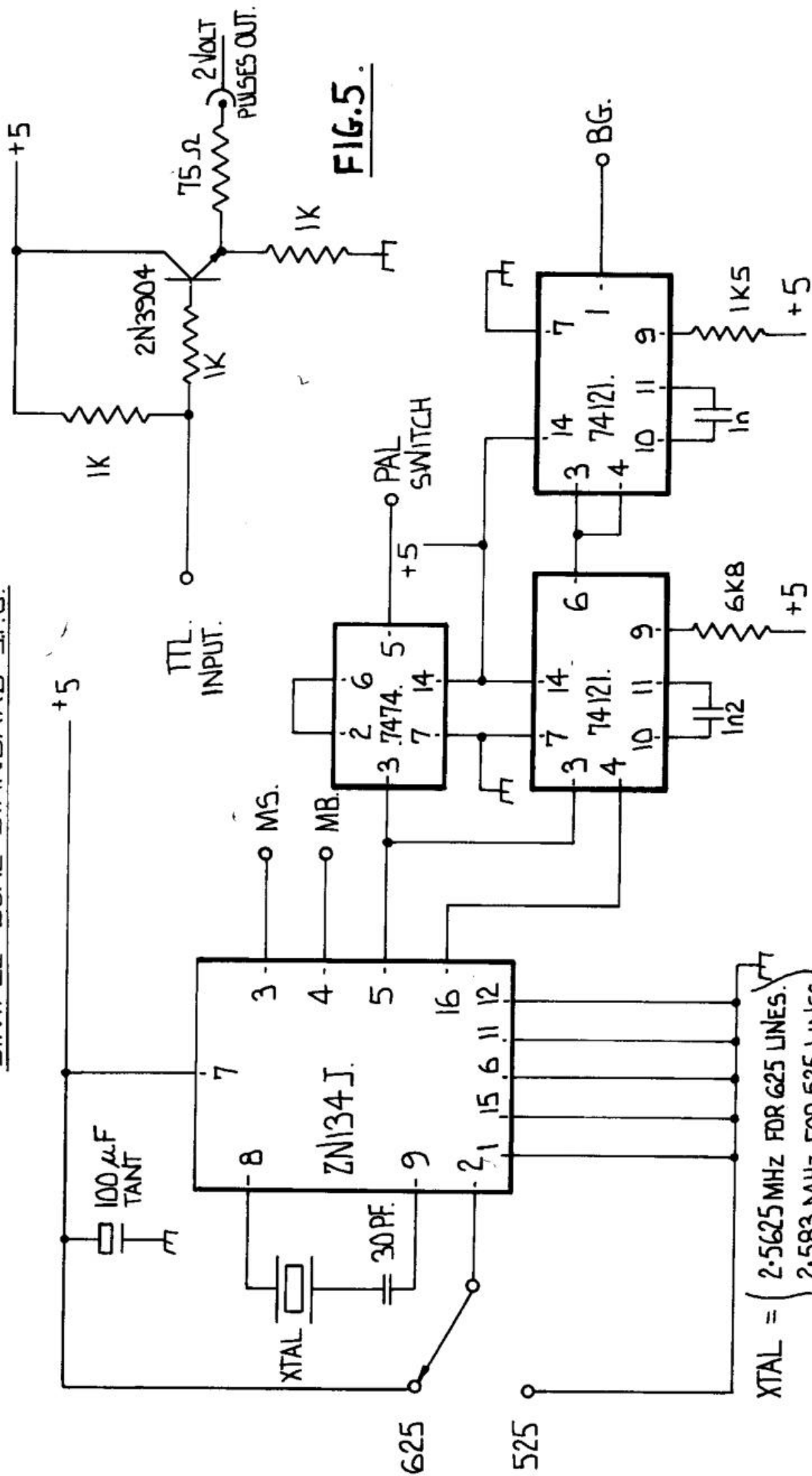

FIG. 5.

FIG. 4.

and 1k5 timing resistors may need their values reducing slightly for 525 in order to position the colour burst correctly.

If the character colour board is to be driven direct with TTL pulses, then these are available directly from pins 3 and 4 of the ZN134J and pins 1 and 5 of the 74121 and 7474.

If a 2 volt pulse distribution is wanted, then Fig.5 shows how to adapt the pulses to 2 volt across 75 ohm system.

At least one Fig.5 should be built to provide the character generator with a locking feed. Drive the emitter follower in Fig.5 with mixed sync, then terminate its output in 75 ohm and feed it into Pin 13 of the character generator.

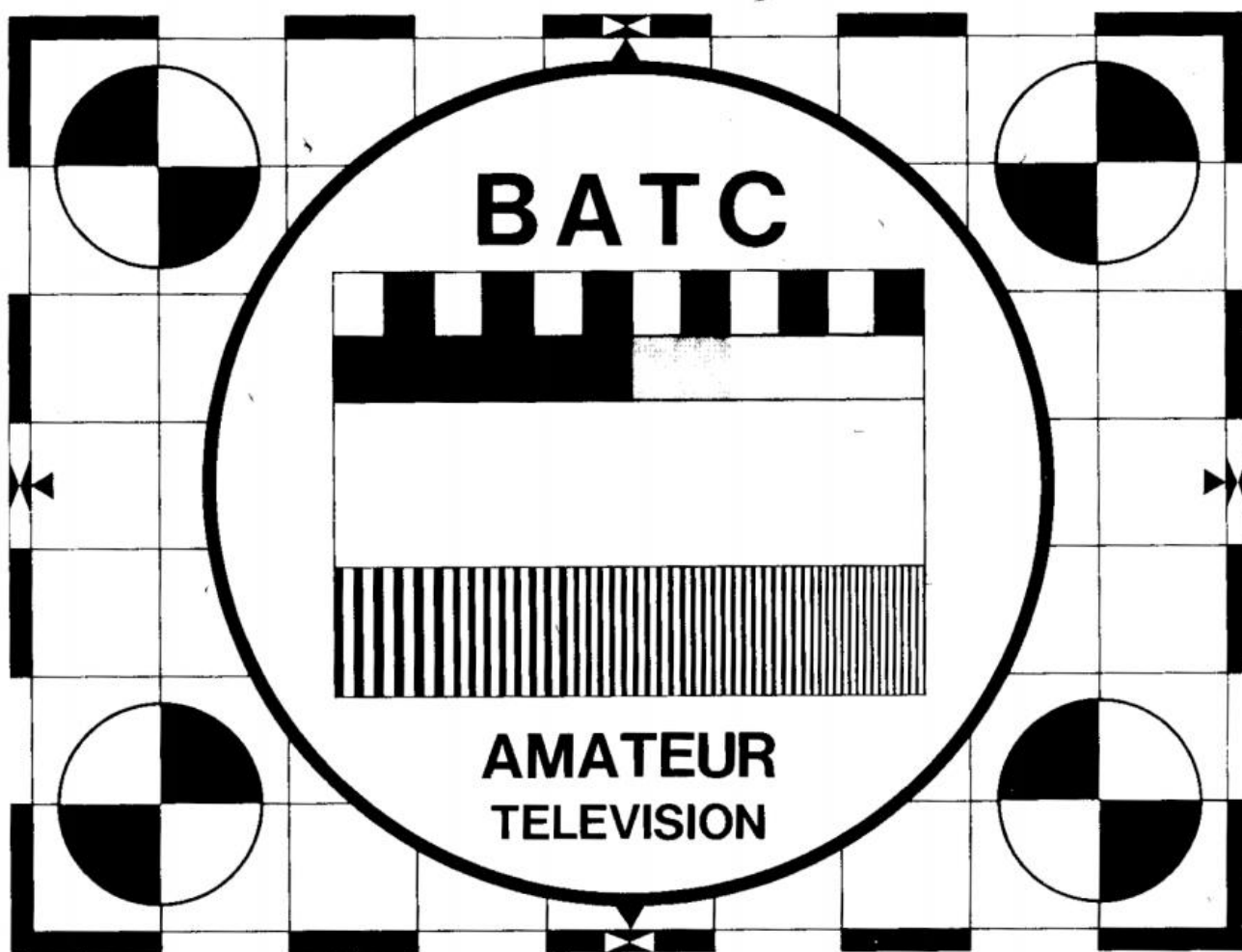

This is the latest test card produced by the BATC. It has been designed especially for amateur television use. The card measures 305 x 225mm and is printed to a high standard. Full documentation is included detailing the functions of the various patterns incorporated within the picture.

The test card is available from Members Services department of the BATC and details are published in each issue of CQ-TV magazine.

VISION SWITCHER

CHAPTER 3

By David Stone G8FNR.

The signal handling of the previous vision switcher design was acceptable for monochrome applications, but, if used for colour, the chroma signal from sources that were not selected, could sometimes be seen on the output. The answer to this problem is to use a slightly more complex crosspoint to switch the video. Fig.3 shows the one used on this improved switcher, it uses three transistors and a few additional resistors.

The new switcher also has eight inputs and the logic has been upgraded, in that vertical interval switching is used on all the banks and a tally system has been incorporated.

The new switcher occupies three printed circuit boards.

The first is the logic and tally board which accepts the commands from the pushbuttons and codes them, in order to keep printed circuit interconnects down, and to process the command signals into a form more readily acceptable by the vertical interval logic, and pushbutton memory circuits. The push buttons used are of the momentary contact non-latching kind. The logic board also has the necessary logic to decode and display tally information. This information is also passed between the boards in a coded form.

Arranging the coding of the commands and the decoding of tally information on one printed circuit board makes it possible to be housed, along with the push-buttons and tally LEDs, to form a remote control. This means that only coded information is passed to and from the remote panel.

The tally lights also provide verification that the commands have arrived at the matrix board and been accepted. Should the commands not be accepted by the matrix board for any reason, say the loss of field drive, then the tally LEDs would not change when selection of a new video source was attempted, showing instantly that a problem has arisen.

The matrix board takes in the coded commands from the logic board and stores them in the 74LS75 latch - this enables non-locking pushbuttons to be used. The information is allowed to pass from this latch to the next 74LS75, so as to only allow picture changes to occur during vertical interval. This technique minimises any subsequent picture disturbance. It is at this point that tally information is derived and fed back to the displays on the logic board.

The coded commands now pass to the 74LS138 where they are decoded back into eight separate commands once again and used to switch the appropriate video crosspoints.

Fig.3 shows one such crosspoint. This is repeated eight times in each of the blocks in Fig.2.

The logic command out of the 74LS138 is a low for the selected source, which is subsequently inverted by the 74LS05. This chip has open collectors so it will allow the base of TR2 on the vision switch to rise to the voltage set by the 10K and 1K8 potential divider in its base (approximately 1.8 volts). This transistor is now switched on and starts to pass current.

The effect of this is to also turn on TR1 by pulling down its emitter below the base potential as set by the two 22K ohm resistors in its base circuit, and to turn on TR3 by pulling down its base voltage. This completes a signal path through TR1 and TR2, both transistors being operated as emitter followers.

All the TR3 transistors in all the video switches share a common load resistor (2K7) but only one TR3 is conducting at any one time, so the selected video appears across this load resistor.

The selected signal is passed to the video distribution amplifier board. The signal is first processed by a differential amplifier, where gain and signal inversion take place. The other half of the differential amplifier is fed with in-phase video to form a negative feedback - the amount of feedback is adjustable, giving a gain control. Its response is also adjustable, which gives variable equalisation - useful when trying to compensate for cable runs.

The signal is inverted back in the next stage and fed to a complimentary symmetry emitter follower stage. This balanced emitter follower provides very good signal handling, especially for colour applications and provides a very low output impedance, so a 75 ohm build up resistor is provided to restore the signal impedance. This very low impedance also enables the signal to be split into four

VISION SWITCHER MATRIX BOARD

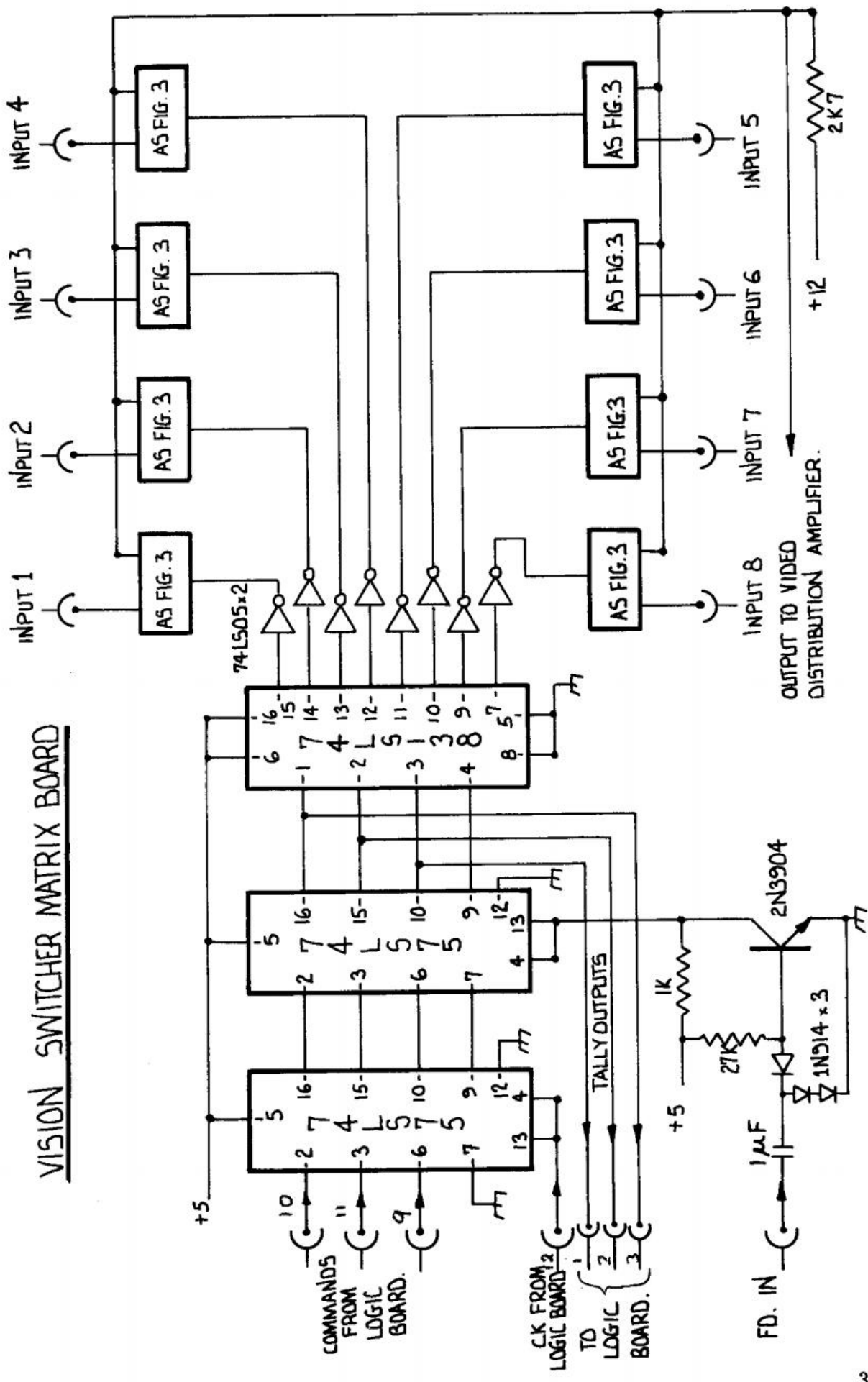

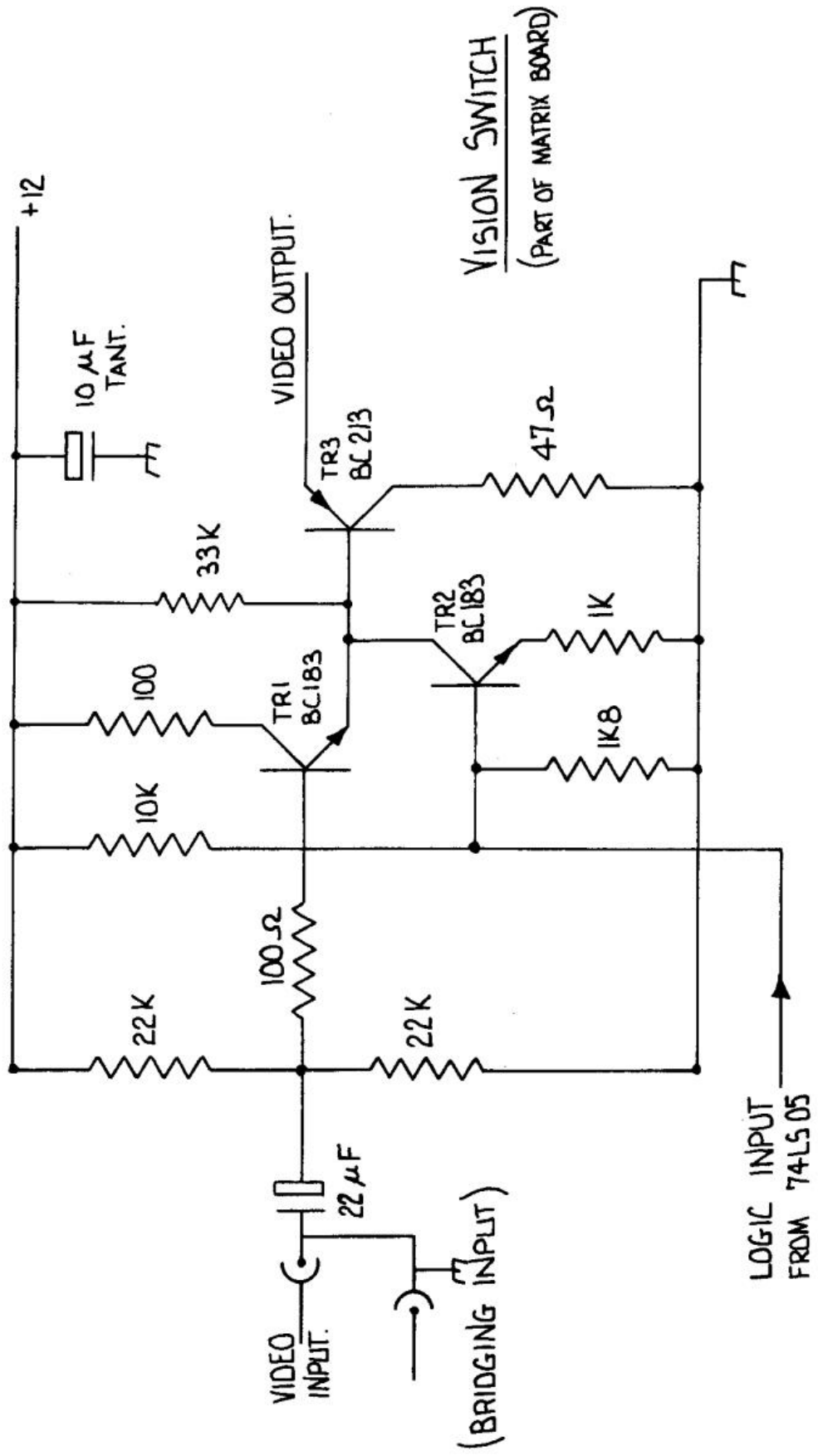

VISION SWITCH
(PART OF MATRIX BOARD)

FIG. 3.

separate outputs, very useful for feeding additional monitors, VTR's etc.

The video distribution amplifier can be used as a stand alone distribution amplifier as well as following the vision matrix board.

The distribution amplifier does have the added complication of requiring a -12 volt rail. This could be considered a disadvantage, but it is a common practice to use split power requirements when designing professional video circuits, as it makes for ease of DC coupling between stages, which gives superior L.F. performance.

The printed circuit boards are laid out so that one logic card contains four logic and tally systems. The matrix board is laid out for two complete channels and the video distribution card carries provision for four distribution amplifiers. This results in three cards being necessary to feed and A, B two channel mixer. By adding a further matrix board, a four bank mixer could be fed.

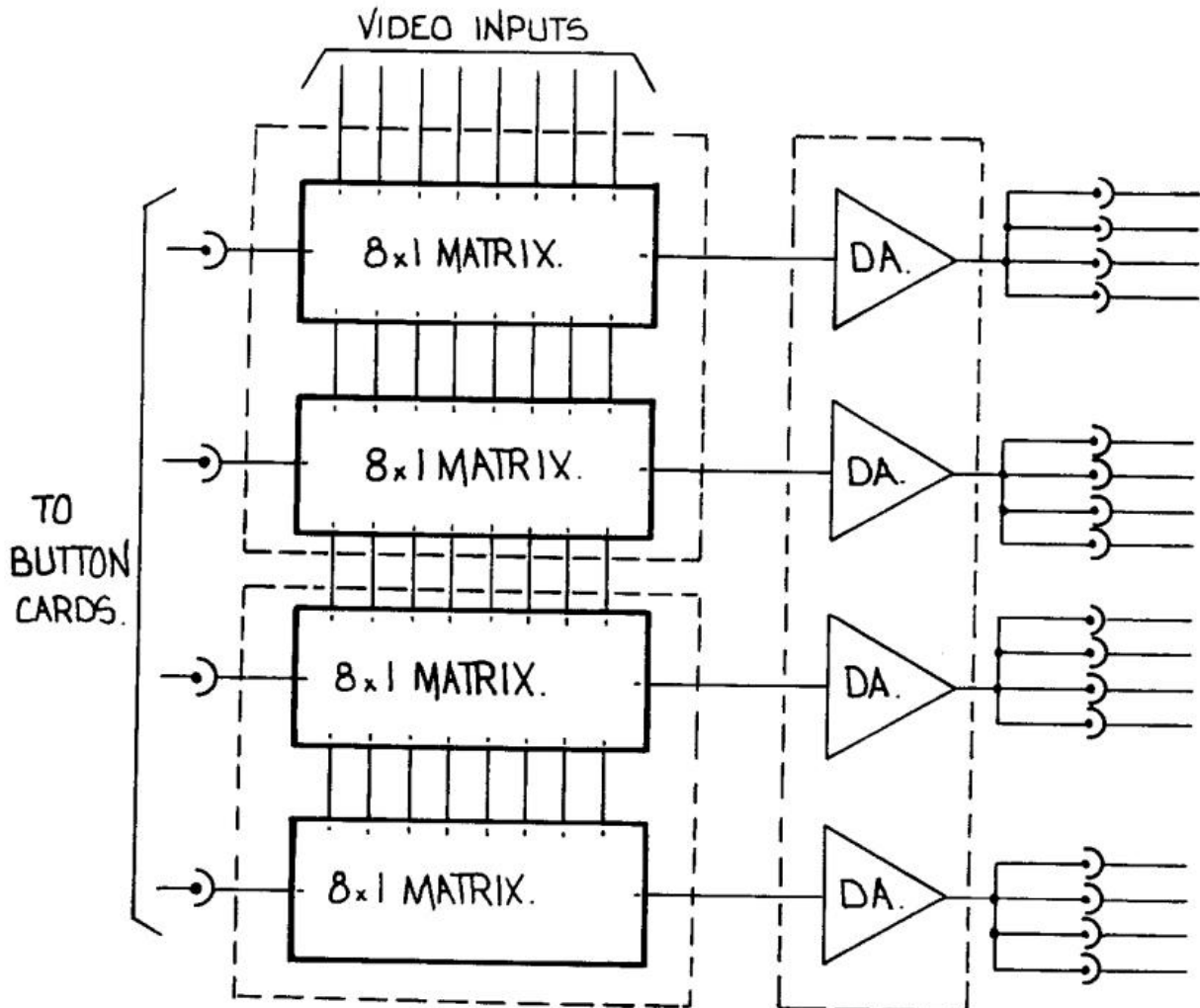

MIX EFFECTS AMPLIFIER

By David Stone G8FNR.
and Chris Short G8GLQ

The next step after vision switching is vision mixing. Being able to switch electronically between cameras and other video sources is very useful, but it is even better to be able to cross-fade or wipe between sources, or even inlay captions across camera pictures.

If you have built up the previous three printed circuit boards (vision switcher), then you will be able to switch any of your video sources into either of the two inputs of the mix effects amplifier. This module gives the added facility of cross-fades between sources, and later, with the addition of a special effects module, that connects to the external key input, wipes of all shapes and directions with hard or soft edges will be possible.

This circuit contains two voltage controlled faders connected in parallel to the video signals and antiphase to the control signal. Thus a single control input can select either video input, perform a fade between two signals, or later with the addition of the wipe pattern generator perform wipes, keys, and inlay captions etc. The performance of the circuit is excellent, keys between identical input signals are invisible and attenuation of the 'off' signal is more than 40dB at subcarrier, invisible on a picture monitor.

Both the video inputs and the key input have feedback clamps to hold the blanking level very accurately, and are worth the extra components required. The voltage controlled attenuators use MC1495 ICs, a wideband analogue multiplier, which although fairly expensive makes construction and alignment easy for the home constructor.

CIRCUIT DESCRIPTION

Each video input is buffered by an emitter follower TR1 etc. The voltage at the emitter is sampled by the gated op-amp IC1. This type of op-amp allows one to set the operating current by means of a current injected into pin 5. If no current is injected the output is high impedance, and when a current is injected the chip behaves like a

VISION MIXER

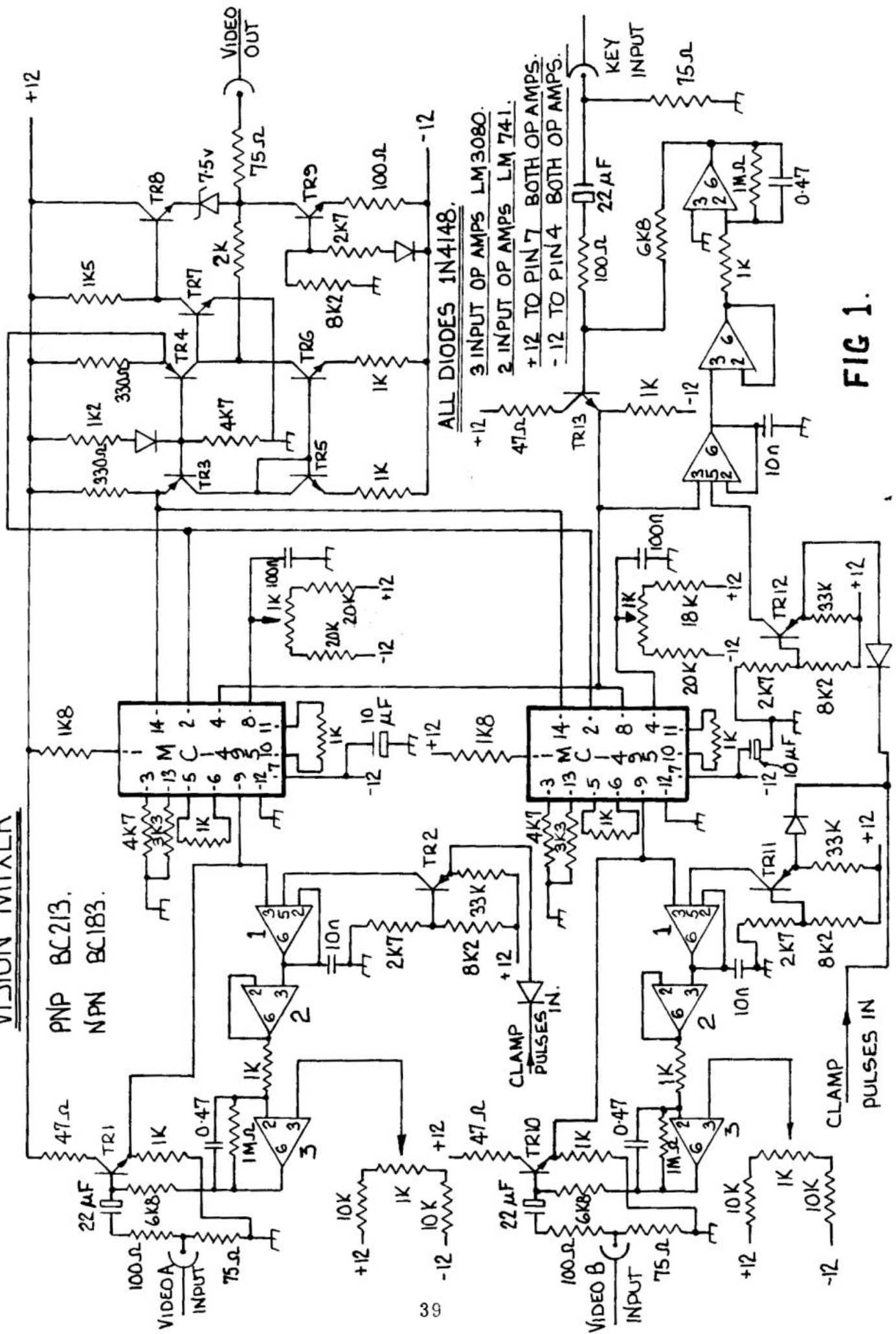

FIG 1.

normal op-amp. A pulse current is switched into pin 5 by TR2 when the emitter of TR2 is allowed to rise to its normal potential during the clamp pulse high time. When the emitter is held low by the TTL IC feeding the clamp pulses to the circuit, TR2 base-emitter junction is reverse biased and no current passes to the gated op-amp. This forms an effective sample and hold circuit sampling the input black level during the clamp pulse and holding this voltage during the rest of the line. The stored voltage on the 10nF capacitor is buffered by voltage follower IC2 and compared by IC3 with a reference voltage. Any difference between the two voltages is amplified and passed to the base of TR1 to correct the error. Thus the voltage at pin 9 of IC4 will be maintained at the reference level during blanking.

The MC1495's give a differential current output, which is fed into the output amplifier TR3-9. When equal currents are fed into the two current source emitters, the output should be 0V. The circuit can thus be checked before the 1495s are fitted to ease fault finding. Current in TR3 passes through current mirror TR5-6, so that the current in TR6 is equal to that in TR4. Thus there is no current imbalance in TR4 and TR6 and thus no current flows in the 2K feedback resistor and the output is at 0V. If a differential current is added to the current sources, it will be seen that twice the applied current is unbalanced at the collector junction of TR4 and TR6. This 'error' current is amplified by TR7 and TR8 moving the output from 0V. This results in a current in the 2K resistor to exactly balance the 'error' current in TR4-6. Thus the collector of TR4 and TR6 work as a current summing point just like the input to a normal op-amp circuit, but with Video bandwidth. Thus the gain of the circuit is controlled only by the 2K resistor provided that the open loop gain is high, which it is. The gain is set to 2 Volts per MA of error current. TR9 acts as a current source of about 30 mA to provide a low output impedance in the negative direction in place of the low value of emitter resistor otherwise required.

The operation of the multiplier is best understood from the data sheet, but the following should suffice. The gain of the multiplier is controlled by the voltage applied between pins 4 and 8 and constants set by resistors. The gain is zero when the voltage is zero and maximum when the voltage is 0.7 volts. The gain is a direct proportion of the maximum for all voltages between 0 and 0.7.

Thus	V = 0.175	Gain = 1/4
	V = 0.35	Gain = 1/2
	V = 0.525	Gain = 3/4
	V = 0.7	Gain = 1

CLAMP PULSE GENERATOR FOR MIX EFFECTS AMP.

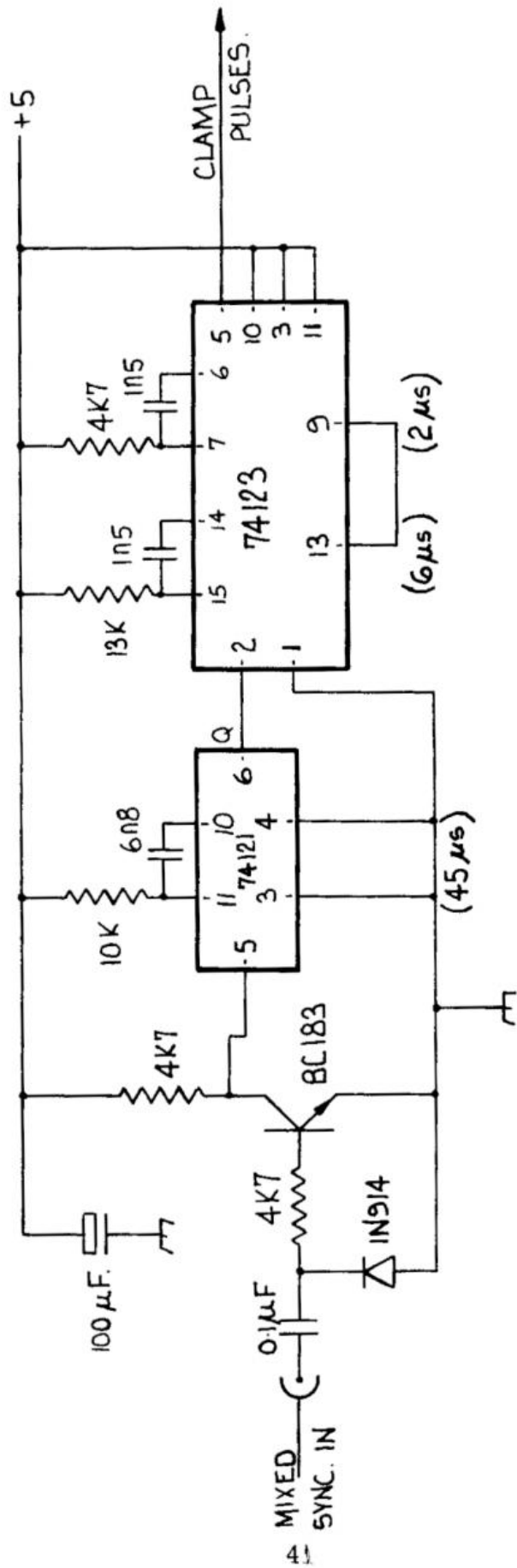

In practice a small error or offset may be present so that zero gain may not exactly correspond with zero volts. This may be adjusted out by means of the pot, provided on pin 8 or 4 of the IC. The second 1495 must be off when the other is on and therefore the control voltage is inverted by changing over pins 4 and 8 and offsetting pin 4 to 0.7 volts. Thus when the control voltage is 0.7 volts one IC has 0.7 volts applied and the other 0.0 volts between their control pins.

It is worth noting that negative control voltages will give inverted video outputs and this can be very confusing during alignment. A slight adjustment of gain of one channel may be needed during alignment and this may be done by changing the 1K resistor between pins 5 and 6 by a few percent or it could be replaced by 910 ohms in series with a 200 ohm preset, although this was not required on the prototype.

The mix effects amplifier is controlled via the input called external key. To perform a mix you will require to build the A.B. cross fader in Fig.3. No provision is made for this unit on the mix effects printed circuit board as it is part of a special effects unit yet to come, that will do much more than a mere mix, i.e. wipes of all shapes and directions with soft and hard edges.

Another use for the external key input is to drive it direct with the video output of the character generator and additional video processing unit (Handbook 1 page 33). By selecting different video signals at the A. and B. inputs, the effect will be a video source with holes cut in it by the characters through which the other video source is visible.

When building the mix effects amplifier, it is essential to use sockets for mounting the MC1495 IC's as it is necessary to be able to remove them easily when setting up the amplifier.

The A.B. cross fader in Fig.3 generates an output which is a variable DC with sync pulses, i.e. as the fader is operated, the generator's output will vary between peak white and black.

To set up the presets on the mix effects amplifier, apply a video signal to both inputs. Fade up the A input and remove the MC1495 in the B channel. Adjust the DC level control (connected to Pin 3 of the op-amp) so that the video at the output sockets has its black level at zero volts when viewed on an oscilloscope.

Now perform a cross fade and the signal will disappear, increase the gain on your oscilloscope and adjust the other pot (pin 8

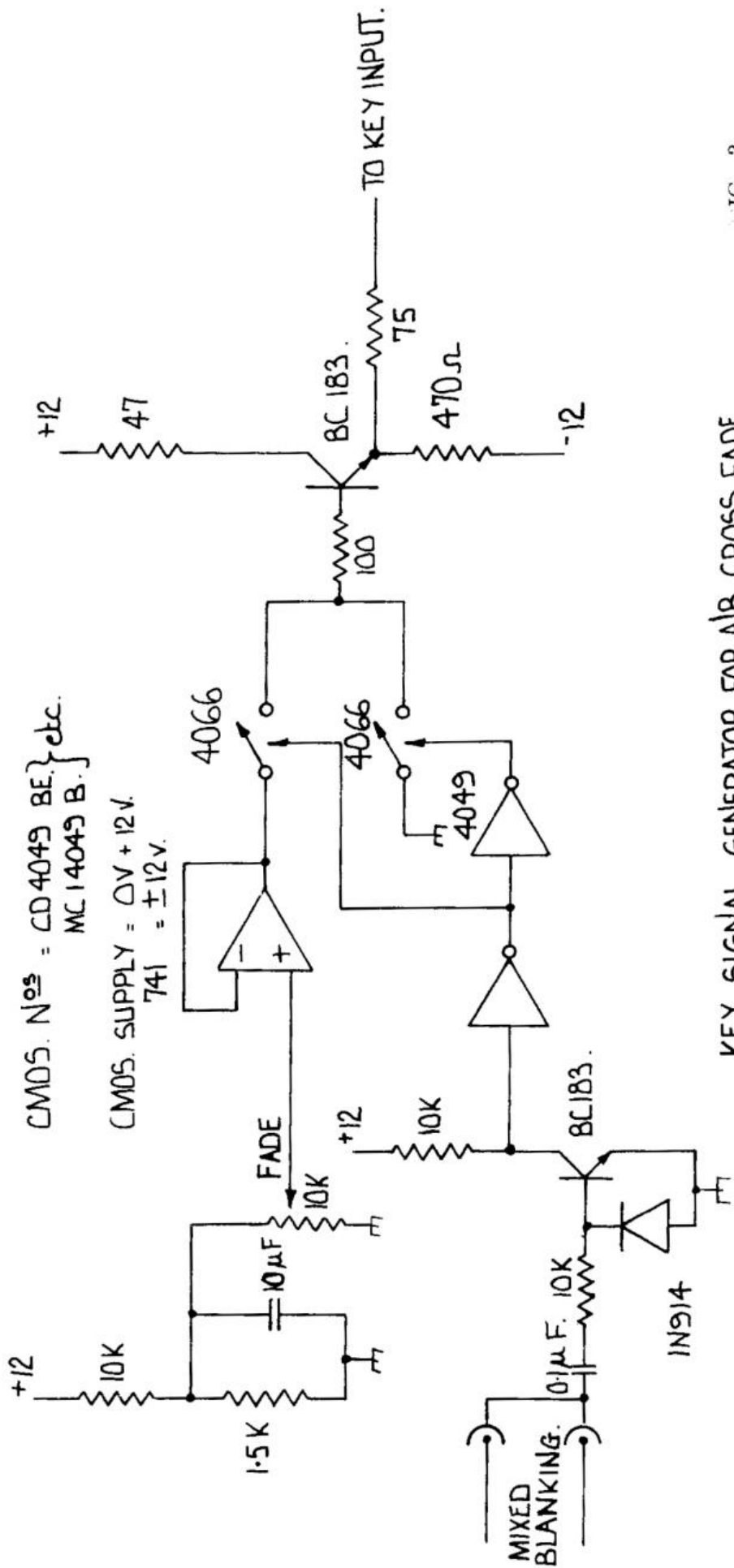

CMOS. Nos = CD4049 BE. } etc.
 MC14049 B. }

CMOS. SUPPLY = 0V +12V.
 741 = ±12V.

KEY SIGNAL GENERATOR FOR A/B CROSS FADE

FIG. 3

of the MC1495) to cancel out any video present at the output.

Fade up the A channel and repeat the DC adjustment, fade down and repeat the other pot adjustment to remove any video signal.

Now replace the MC1495 in the B channel and remove the one in the A channel. Repeat the above adjustments for the B channel setting the DC pot for a black level corresponding to zero volts as viewed on an oscilloscope.

Perform a cross fade, make sure the signal disappears, and remove any residual video with the pot connected to pin 4 of the MC1495.

Reinstall the MC1495 into the A channel and check the DC adjustments by cross fading between channels, slight adjustment may be necessary along with the signal pots.

Try a cross fade between colour bars and black and adjust the signal pots with the black source faded up.

PCB's

Printed circuit boards are available for many of the projects contained in this handbook. Full details may be obtained from the Members Services dept order form with each copy of CQ-TV magazine.

Boards are also available for the original (blue) handbook, details of which may again be taken from Members Services order form.

'MEMBERS SERVICES' ITEMS ARE ONLY AVAILABLE TO CLUB MEMBERS.

COLOUR SYNTHESIZER

By David Stone G8FNR.
and Chris Short G8GLQ.

This equipment was designed to produce multi-coloured captions from a monochrome caption camera. It allows colour of any saturation or luminance to be allocated to one of five ranges of caption brightness. All of the transition levels are fully variable and less than five levels may be used over the entire input range by setting the unused levels to zero resistance. The synthesizer output is an RGB signal suitable for feeding a standard PAL (or NTSC) coder. The output of any camera may be synthesized producing some colourful 'Top of the Pops' effects. It should be realised that five levels are not practical for captions with an amateur camera, although they may be used with two or three levels and with five levels for special effects.

CIRCUIT DESCRIPTION.

Incoming video is buffered by an emitter follower, and is then clamped to 0 volts. The clamped signal then passes to a three transistor amplifier whose gain is set to provide 5 volts peak to peak from the video component of the signal at pin 3 of each comparator. The blanking level at the output of the amplifier is varied by the black level control to compensate for poor camera signals. The maximum video signal is clipped at +5 volts by the amplifier to keep the video within the operating range of the comparators. The chain of four comparators give five output states for which transitions are set by the voltages applied to the negative inputs of the comparators. These voltages are set by the front panel 'transition level' controls (VR2-5). The comparator outputs are then priority coded to generate an output from the highest level only and then blanked by the external mixed blanking signal. At this point, selected outputs are available which may be used as key inputs to an external keyer or mixer.

An internal setting up aid is included which inserts five inputs across the top of the picture, or down the whole frame, to assist in the adjustment of the colour and transition level controls. An oscillator running at a multiple of line frequency (7413) is gated to give a five-phase line locked clock from a decoded counter (4017).

5-LEVEL FULL COLOUR SYNTHESIZER.
SIMPLIFIED BLOCK DIAGRAM

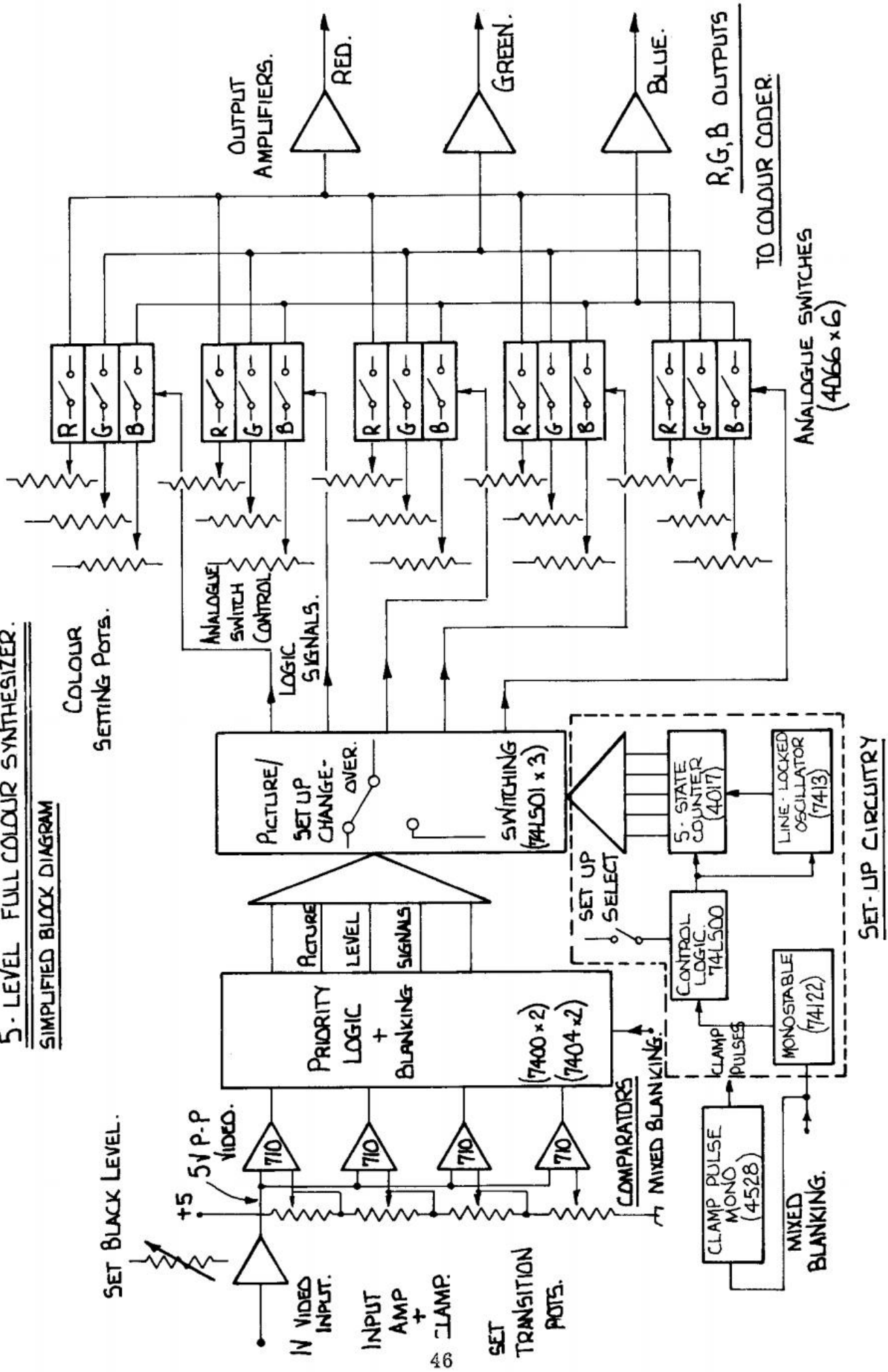

THE BRITISH AMATEUR TELEVISION CLUB



GENERAL INFORMATION SHEET

and

MEMBERSHIP APPLICATION FORM

October 1982

THE BRITISH AMATEUR TELEVISION CLUB

The club was founded in 1949 to inform, instruct and co-ordinate the activities of amateur radio enthusiasts experimenting with television transmission, and to liaise with other enthusiasts engaged on similar work overseas. The club is affiliated to the Radio Society of Great Britain and has a representative on its .H.F. committee.

Members are involved in many aspects of television including transmitting, receiving, closed circuit TV, video recording methods, special effects generation, colour TV and slow scan TV.

CLUB PUBLICATIONS

A quarterly magazine called CQ-TV is issued to all members, it features circuits, constructional articles, photographs, news of members activities, regular columns and news items. Contributions to the magazine are welcome and members are invited to send in news of their activities and in particular any articles or practical hints, tips and ideas that they may have. Some back copies of CQ-TV are available from BATC publications, details of how to order are given in the magazine.

CLUB FACILITIES

The club provides a service to its members by supplying various special items, such as vidicon camera tubes, bases, scanning and focus coil assemblies, special lens mounting flanges, vision reception reporting charts, test cards, printed circuit boards, headed notepaper, lapel badges etc. Full details of how to order these and other items are given in CQ-TV.

CLUB CONVENTION

The club holds a convention once every two years at which members are invited to display their equipment and have an opportunity to exchange ideas and discuss their problems with other members.

During the convention the General Meeting of the club is held when the officers of the club are elected and any other business discussed.

CONTESTS AND AWARDS

The club organises television contests to help promote activity and has it's own graded award scheme for personal on-the-air achievement.

B.A.T.C. MEMBERSHIP APPLICATION FORM

Send this form together with your remittance to the Hon. Membership Secretary B.A.T.C.

I (BLOCK CAPITALS PLEASE)

INITIALS	
SURNAME.	CALL SIGN.
ADDRESS.	
TOWN.	
COUNTY.	POST CODE.

wish to join the British Amateur Television Club.

- Tick Jan to Dec 83 + All 1984 = £8.00
- Tick April to Dec 83 + All 1984 = £7.00
- Tick July to Dec 83 + All 1984 = £6.00
- Tick Oct to Dec 83 + All 1984 = £5.00
- Tick All 1984 (Jan to Dec) only = £4.00

£.....

Please note :- These rates may not be valid after Jan 1984.

Please write to the Membership Sec. for the current rates enclosing an SAE.

No Lapel Badges at 50p each £.....

No Back issues of CQ-TV at 75p each £.....

TOTAL REMITTANCE ENCLOSED £.....

Please pay by cheque/P.O./M.O. made payable to B.A.T.C.

Overseas applicants should pay by a cheque drawn against a London bank.

Signed Date

NOTE :- Orders for other club sales items should be sent separately as per details given in the current issue of CQ-TV.

FOR OFFICE USE

Date	Receipt No	Treasurer
Mags sent	Cash Received	Mailing list

READ CQ-TV

**AND KEEP IN TOUCH WITH
AMATEUR TELEVISION
THROUGHOUT THE WORLD.**

**Join the B.A.T.C. by completing the
application form and forwarding with your
remittance to:-**

Hon. Membership Secretary, B.A.T.C.

**Mr. B. SUMMERS.
13 CHURCH STREET,
GAINSBOROUGH.
LINCS.**

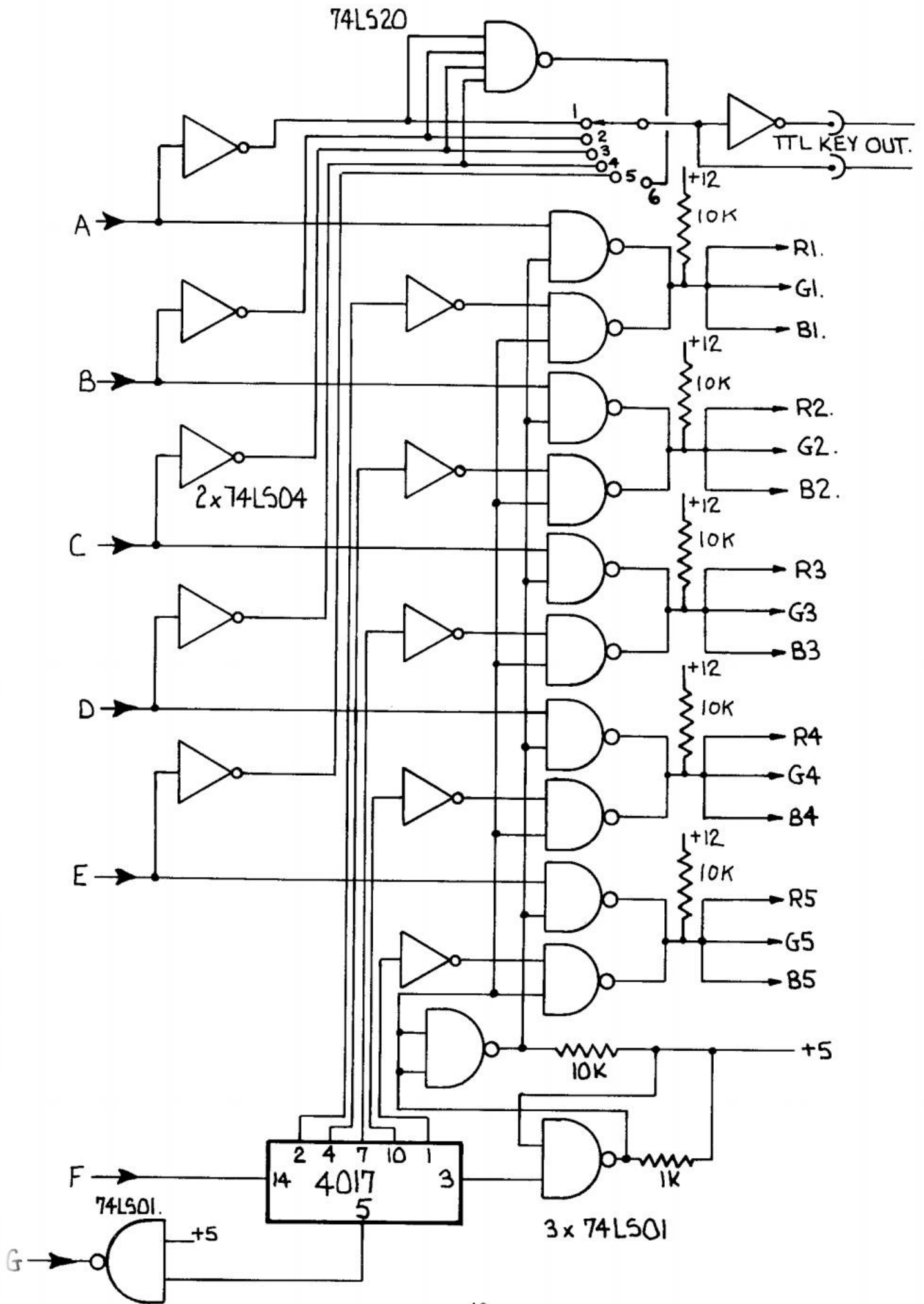

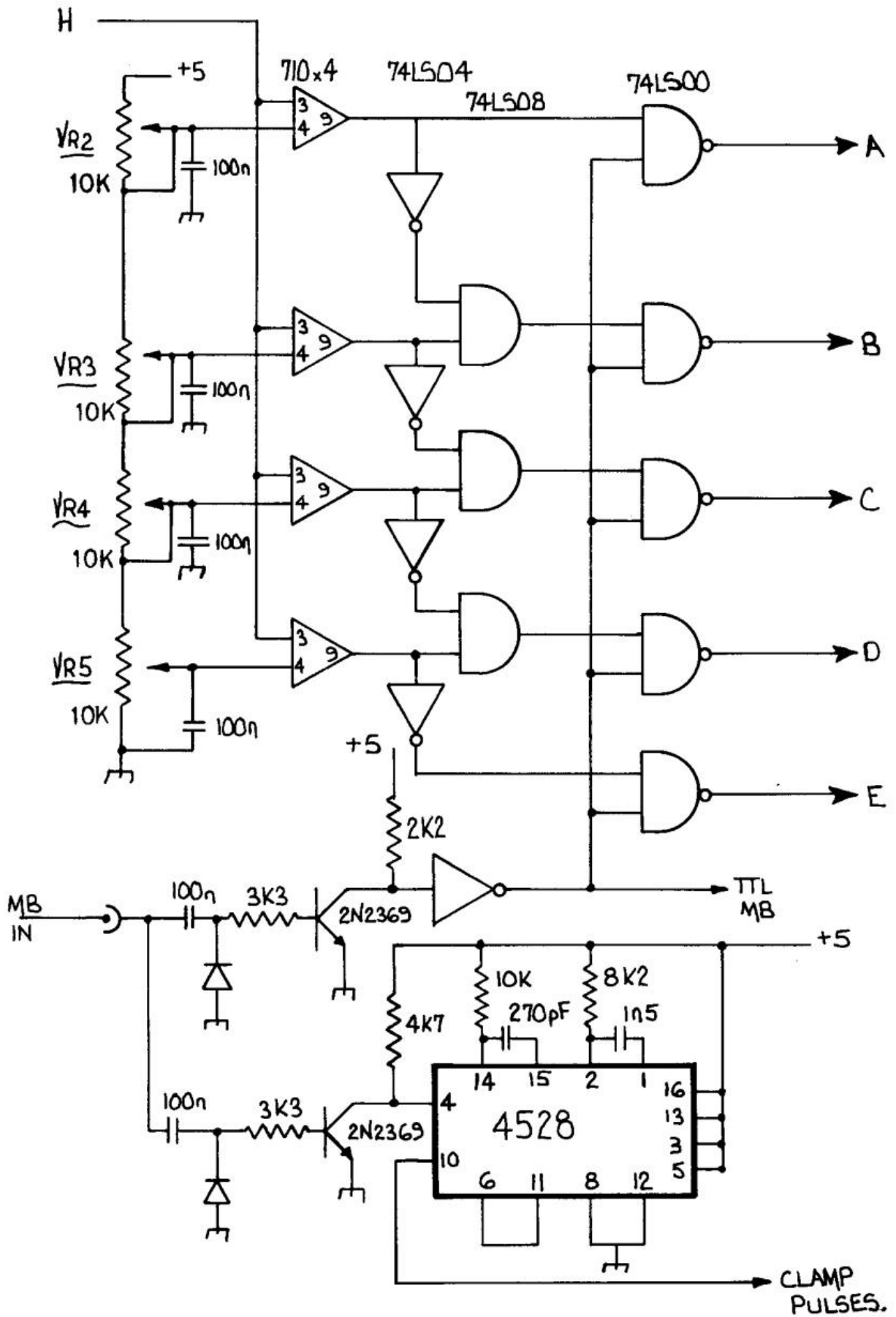

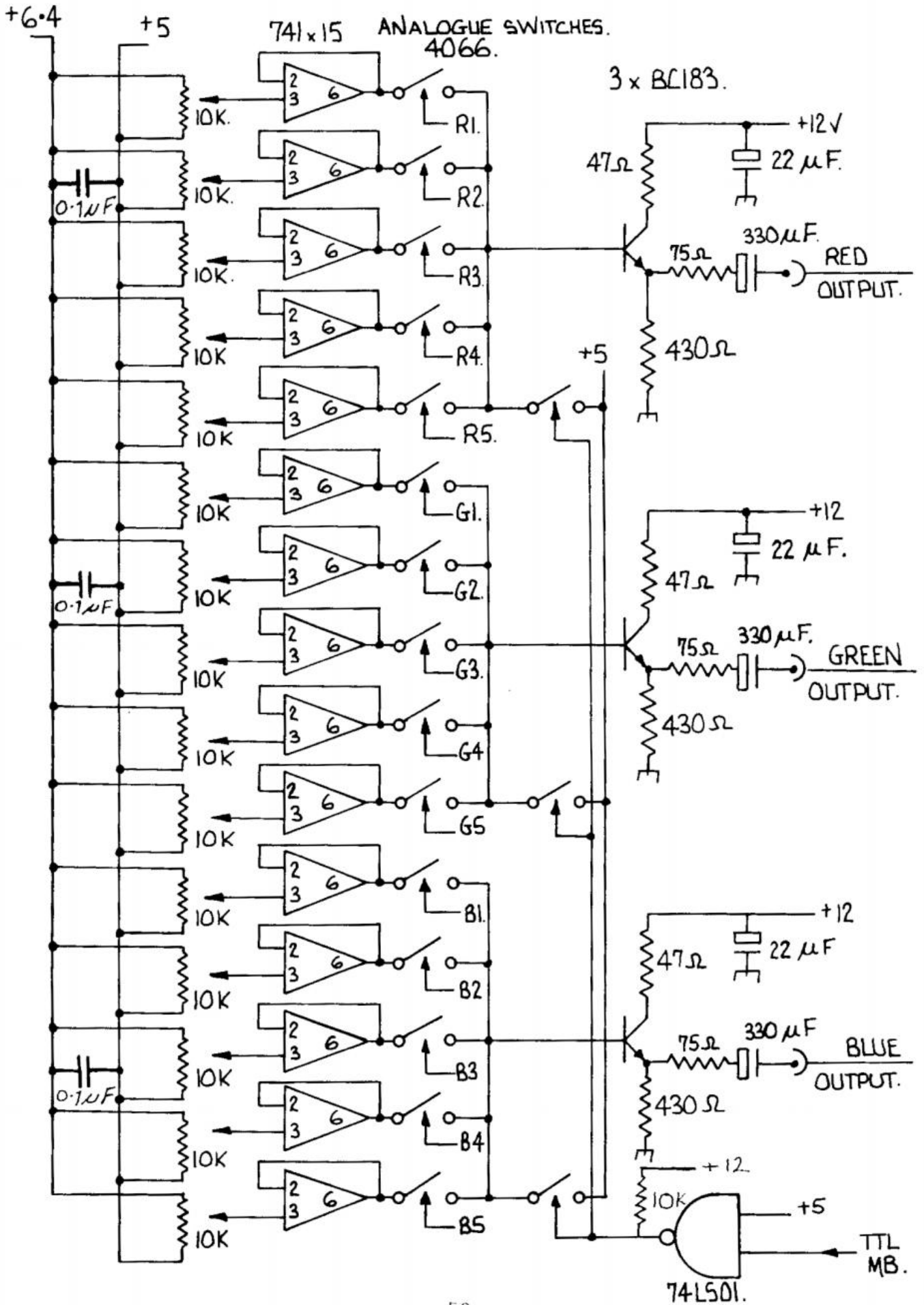

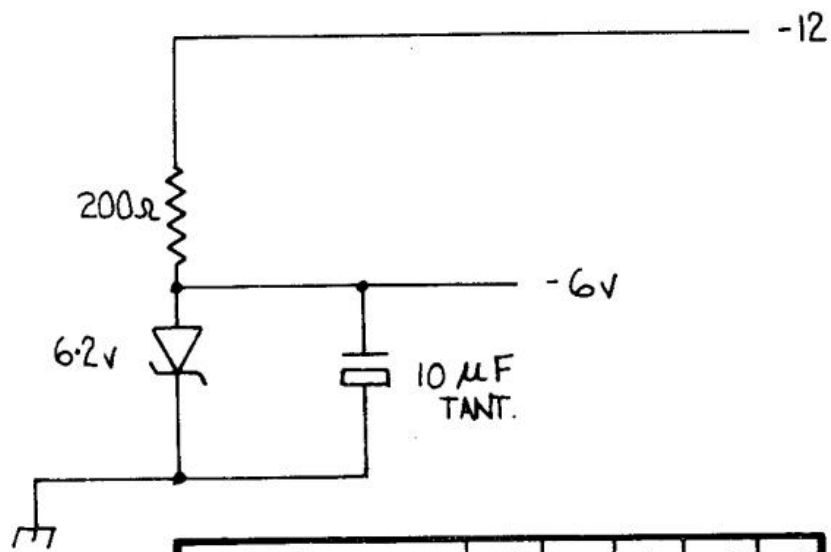
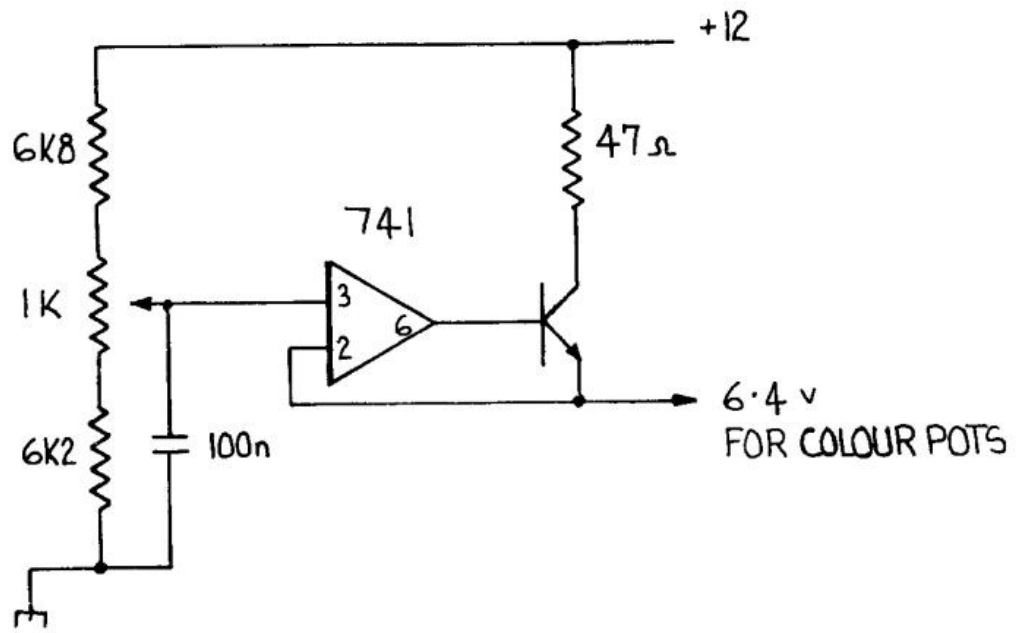

IC TYPE	+12	+5	⌈	-12	-6
4066	14		7		
710	11		2		6
741	7			4	
7400 7401 7404 7408		14	7		
74122		14	7		
4528		16	8		
4017		16	8		

Whilst the setting up scale is displayed, the output from this counter is used to drive the RGB control circuit. During the rest of the frame, the comparator outputs are displayed, corresponding to the synthesized video input signal.

D.C. voltage levels between 5.0 and 6.4 volts are derived from the front panel Red, Green and Blue controls. These voltage levels are switched via CMOS analogue switches to produce the RGB signals directly. The priority coding ensures that only one switch is on at any time and an extra switch connects the output to +5 volts during blanking. The switch outputs are buffered by emitter followers and are connected to the rear panel RGB output sockets. A simple regulator sets the maximum voltage to the RGB controls, to 1.4 volts above the +5 volt rail. The output of each control is buffered by a voltage follower to isolate the controls from one another. The mixed blanking input is integrated to provide a field start pulse for starting the set-up mode monostable at the top of the field.

Layout of the analogue switches and output amplifiers is critical to good performance.

The set of printed circuit cards available for this project incorporate a ground plane in the design. Construction of this project in any other way than on these printed circuit boards is not recommended.

Power supplies are conventional with three-terminal regulators for the + and -12 volts and +5 volts rails.

Wirewound pots are recommended for all controls as carbon types do not last well when used for DC.

Once familiarity has been gained with the controls many good captions and special effects may be produced, results being as good as many professional units.

The External Key outputs will mate into the special effects card which will be the subject of a later publication. If you want to use it direct into the mix effects amplifier, then a small series resistor of 330 ohms must be incorporated to convert the TTL level into a .7 volts source when terminated in 75 ohms.

70 cms V.S.B. TRANSMITTER

CHAPTER 4

By Paul Marshall G8MJW.

INTRODUCTION.

This transmitter design offers 1w peak sync. output on the 70cm band. It is I.F. modulated and filtered giving true V.S.B. (Vestigial Sideband) output. At 1 Watt output the transmitter is suitable for short range contacts, or it can be coupled to a LINEAR amplifier to give more output (see later).

Why V.S.B. and I.F. modulation/filtering? The 70cm amateur band offers 8MHz to the T.V. amateur. A standard V.S.B. System 1 (British 625 line) broadcast signal occupies 3MHz and takes the form shown in Fig.1.

The purpose of employing V.S.B. is to reduce the bandwidth required compared to the equivalent A.M. which would need 12MHz.

The receive characteristic has a -6dB slope through zero in order to achieve an approximately flat frequency response when the signal is demodulated.

Achieving a true V.S.B. transmission is a difficult proposition for the amateur due to the filtering required and the high degree of linearity need in any subsequent mixing and/or amplification.

Traditionally, amateurs have either limited their transmitted video bandwidth (say to 3MHz) and used A.M. (a bandwidth of 6MHz), or filtered at U.H.F. using inter-digital or cavity based U.H.F. filters. The former precludes the transmission of colour and the latter is difficult or impossible for the average amateur with limited test equipment and resources.

This design uses the modern broadcast transmitter approach of modulation and filtering at an I.F.. This has been tried before but has fallen into disuse due to the difficulty of alignment, particularly of

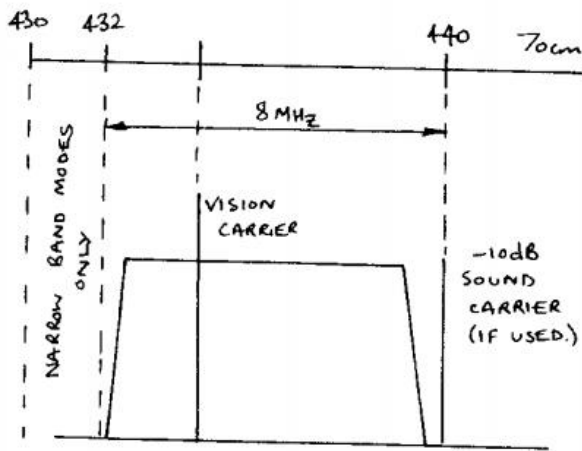
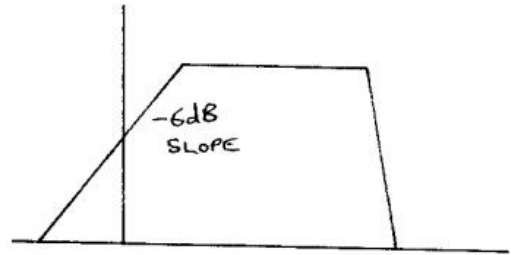

FIG. 1. BROADCAST V.S.B.
+ 70cm BAND



RX. V.S.B. FILTER CHARACTERISTIC.

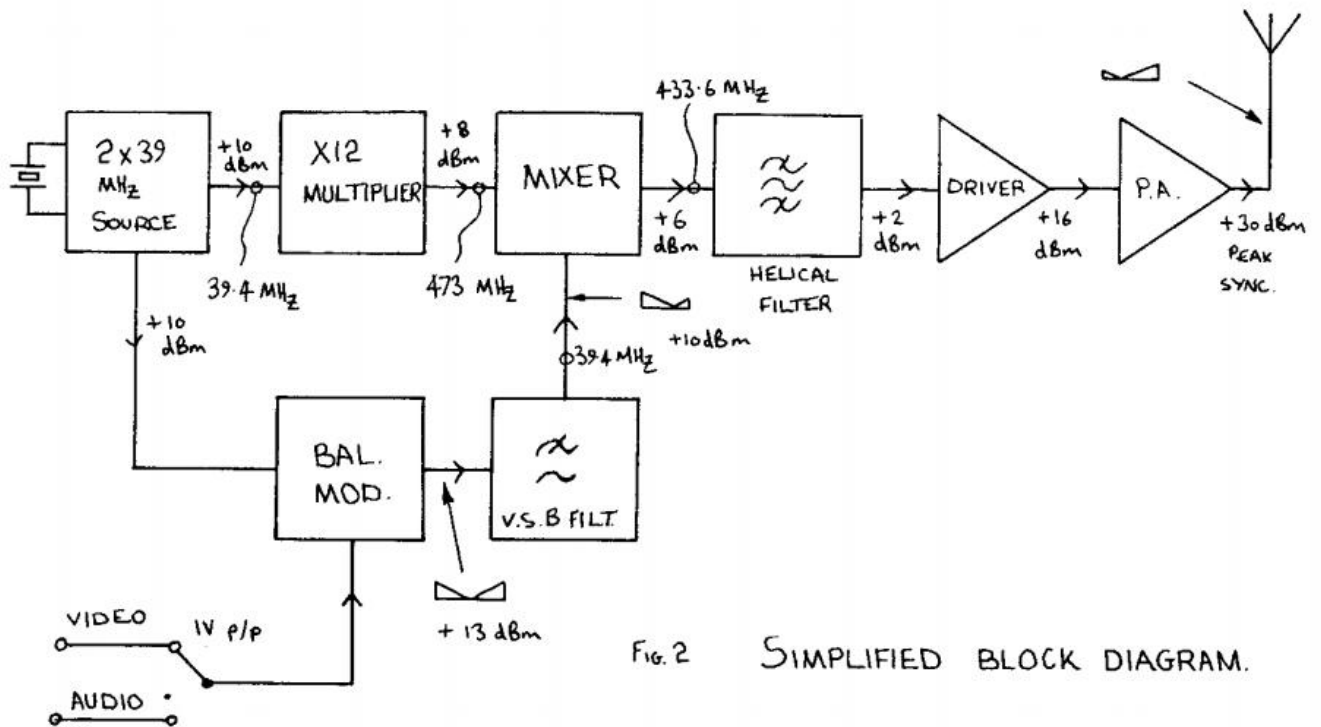

FIG. 2 SIMPLIFIED BLOCK DIAGRAM.

(0 dBm \equiv 1mW INTO 50 Ω , 10 dBm \equiv 10 mW, 20 dBm = 100mW
ETC. LEVELS SHOWN ARE TYPICAL.)

the V.S.B. filter. The reader may now be asking why not use an S.A.W. filter as used in modern T.V.s? This would be very desirable, but it has the receive V.S.B. characteristic, and due to the time delay (5uS) through the device, parallel or series path compensation using additional inductors and capacitors, cannot be used. (Transmit V.S.B. filters are available but, at £300 each, they are beyond the amateur's pocket). The V.S.B. filter employed is a very simple unit and is easy to align using pre-wound inductors.

Referring to Fig.2, it can be seen that the design is quite simple in essence, employing as few stages as possible. The channel filter seen after the mixer is a helical pre-aligned type.

The transmitter is modular to further facilitate alignment - it was considered that screening of individual stages would be more easily accomplished using small "modules" and that a small module is less "daunting" to align. Modular construction also means that anyone wishing to build a T.V. transmitter to a different scheme may wish to use part or parts of this one.

BRIEF SPECIFICATION.

OUTPUT:	1w P.S.
O/P SIDEBAND S/C REJECTION:	25dB (Typical Broadcast Tx. Specification)
DIFFERENTIAL GAIN:	5%
DIFFERENTIAL PHASE:	6 deg.
INPUT:	1V peak-to-peak 75 ohms
VISION CARRIER:	433.6MHz
STANDARD:	System I
SUPPLY:	+11 to +14V d.c.

N.B. Differential phase and gain can be optimised given the right test equipment - a typical figure is hard to define - PAL colour is very tolerant of such defects anyway.

R.F. CONSTRUCTION.

Designing an R.F. project for the amateur constructor poses many problems in the actual construction and availability of parts. The intending constructor must use good quality trimmers, resistors, fixed capacitors, etc. Problems of low Q in stages can sometimes be attributed to poor trimmers and/or chokes.

It is very important to use only branded 2N3866's from well-known manufacturers - many so-called 2N3866's available are not first grade. They may be O.K. at V.H.F., but of no use at U.H.F. The higher

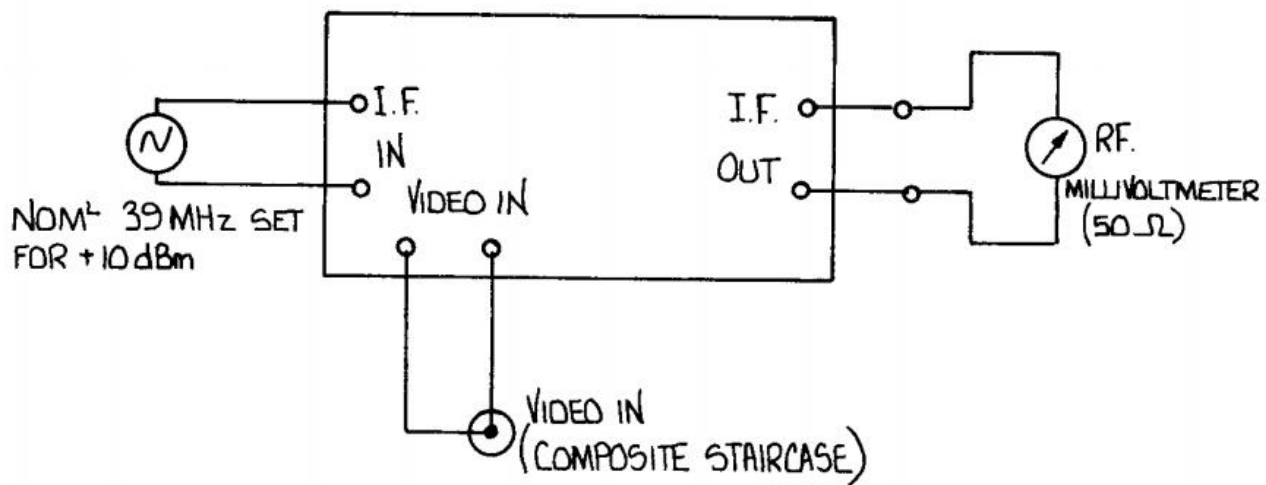
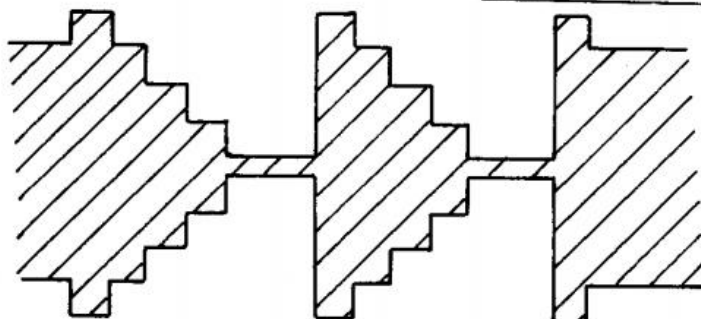
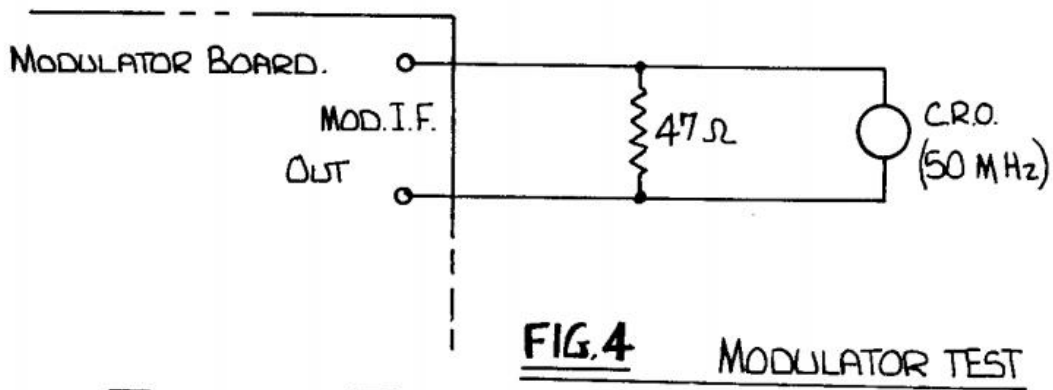

FIG.3 MODULATOR BOARD



gain 2N3866A can be used to some benefit.

Boards 5, 6 and 7 require "edging" with tinned copper foil as plated through hole boards are not cheaply available. Edging involves making tinned copper foil strips about $\frac{1}{4}$ " wide and wrapping them round the board edges to complete the earth plane between top and bottom of the board. Careful soldering all along the edges on both sides is required.

Please note that all components are mounted on the top side of boards 5, 6 and 7 (no holes are required except for the BFR90 and BLX67 transistors to sit in).

Make sure each board functions on its own before trying to couple up the whole transmitter. Steady, patient construction is the key.

Each module should be screened from its neighbour, die cast boxes are ideal, if a little expensive. Tin plate boxes or a segmented chassis serves just as well. All U.H.F. inter-board or aerial connections should be made with good quality coax. (Not video grade, even though the runs may be short.) Feedthrough capacitors of 1 nF should be used in the +ve power feeds to the units.

1. I.F. GENERATOR.

The I.F. Generator provides two 39.4MHz outputs at approximately +10dBm each. A 13.4860MHz Pierce Crystal Oscillator is the base, followed by an X3 Multiplier, coupled via a double tuned circuit (giving low harmonic content) to a single tuned output circuit. Pre-wound coils are used for simplicity.

Alignment requires a wavemeter and an R.F. millivoltmeter and/or a 50MHz or better oscilloscope. Using either the wavemeter (set to 13MHz) or the oscilloscope adjust 1L1 and 1C1 for maximum 13.4860MHz. (If a frequency counter is available, the capacitor across the crystal may be adjusted until 13.4860MHz precisely is achieved.)

Terminate both outputs with 47ohm resistors. Transfer the wavemeter or oscilloscope to 1T1 and tune the cores for maximum 39MHz. Move on to 1L2 and adjust it for maximum 39.4MHz. Using an R.F. millivoltmeter (50ohms), check that each output is at least +10dBm. (0.707V R.M.S.). (Ensure that the other output is terminated.) Second and third harmonics should be typically better than 40dBm down.

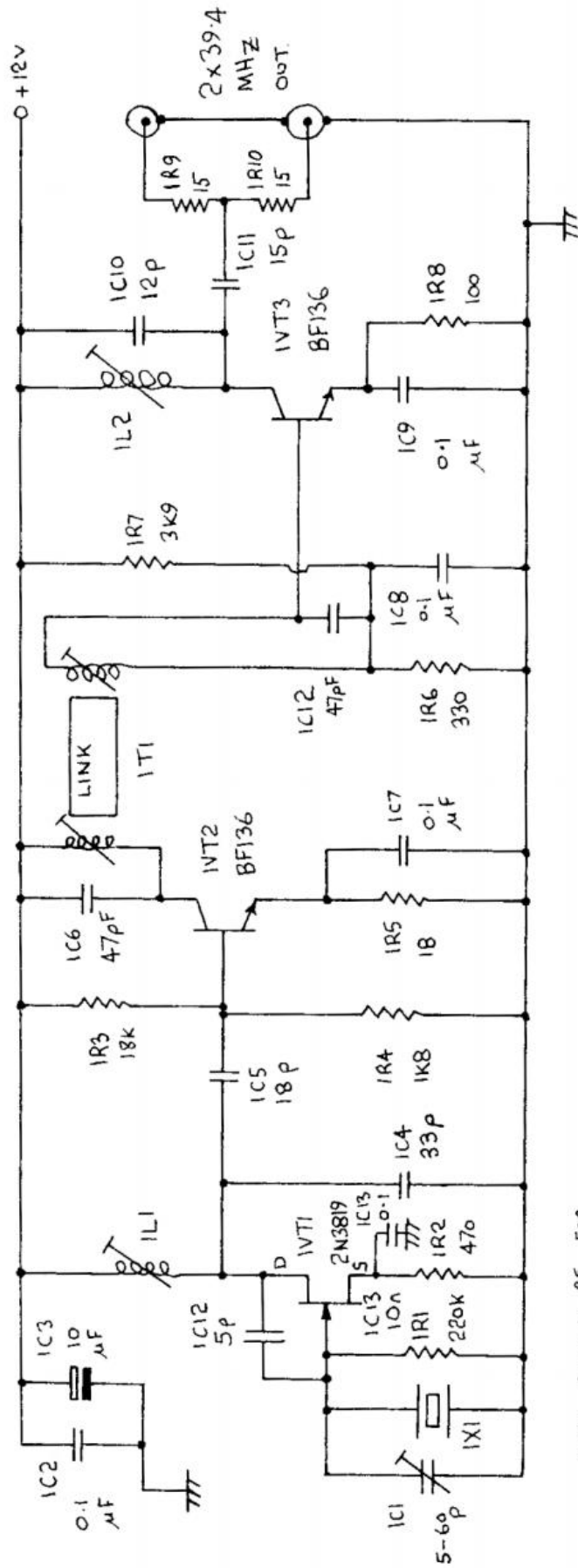

FIG. 5. 1. 2 X 39 MHZ. SOURCE.

2. VIDEO MODULATOR

The modulator uses a conventional double balanced diode bridge technique, fed by a D.C. coupled video amplifier/inverter. The input and output are buffered by simple amplifiers. No clamping or D.C. restoration of the video input is performed as it was considered that, in a typical station, the video fed to the transmitter would be clamped anyway - if not, there are plenty of standard circuits available.

Construction is quite straightforward, providing care is taken with the transformers. Other cores such as toroids could be used, providing the ferrite is of a grade high enough to cope with the frequency (39MHz).

Alignment is as follows:-

Set oscillator to 39.4MHz and check for a nominal +10dBm output. Replace the R.F. millivoltmeter by the circuit shown in Fig.4.

Adjust 2RV1 for waveform shown.

If a 50MHz Oscilloscope is not available, a diode probe can be used with a 5MHz Oscilloscope, and the resulting video waveform adjusted for best "shape" (i.e. minimum crushing). The 47ohm termination must be used.

For best performance, adjust the values of 1C6 and 1C12 for maximum modulated R.F. out. (If other cores are used, this will certainly have to be done.)

3. MULTIPLIER

The Multiplier is a conventional design using an x2,x2,x3 configuration. The first stage is lightly biased to improve sensitivity, the following stages operate in Class C.

Alignment requires the use of a wavemeter and preferably an R.F. millivoltmeter. Due to the low input frequency (39MHz), the technique of tuning for maximum collector current on each stage cannot be recommended. (It may be used as a "fine tune" once a rough alignment using a wavemeter has been accomplished.)

Either inject a 39MHz +10dBm signal from a Signal Generator into the input, or use an output from a completed 2 x 39MHz board. (Terminate the unused output in 50ohms or connect to the modulator board.) Using a wavemeter in close proximity to 3L2 and 3L3, tune for maximum 80MHz. Transfer to 3L6 and 3L7 and turn 3C9 and 3C10 for

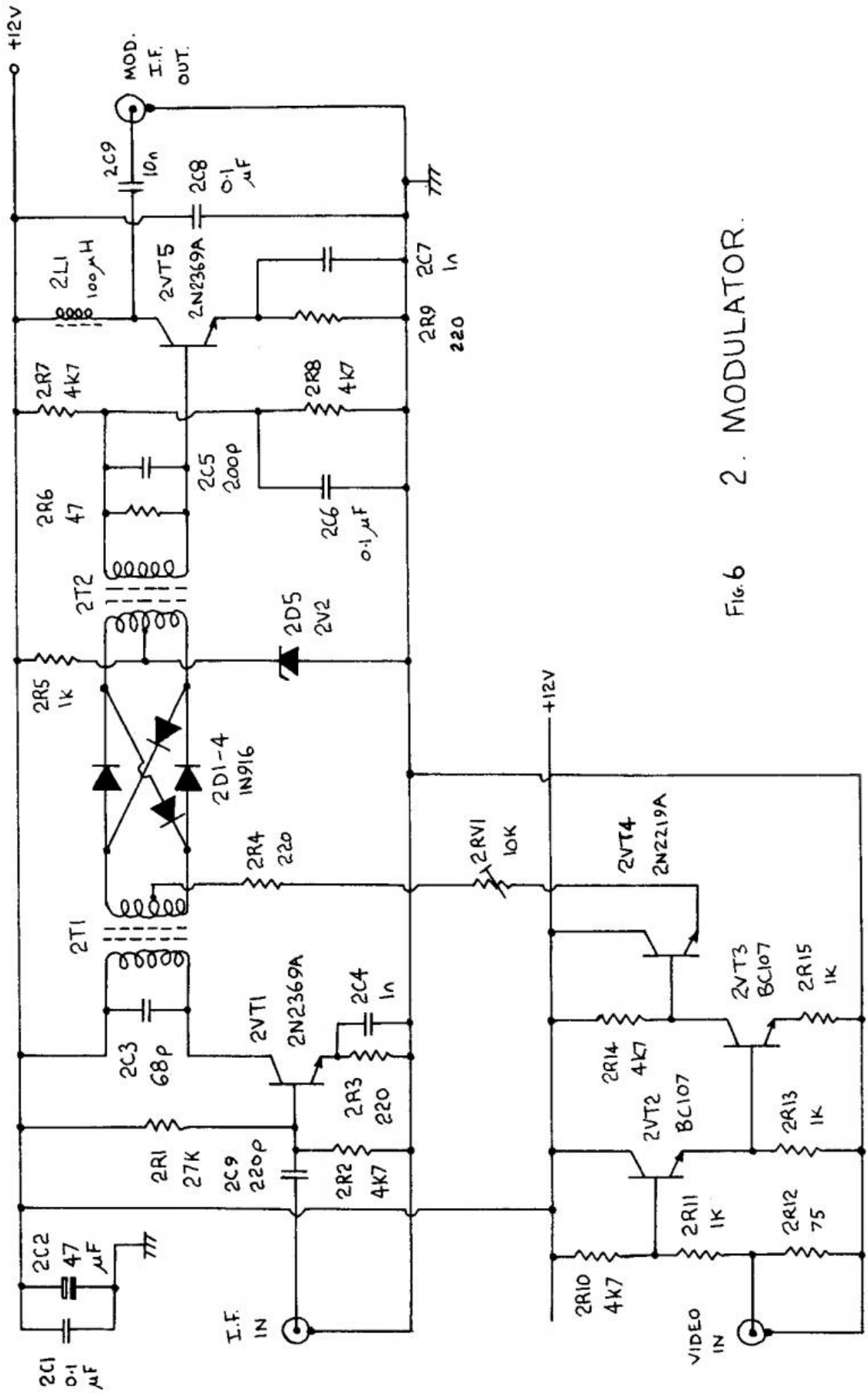

Fig. 6 2. MODULATOR.

maximum 160MHz. Finally, connect a 50ohm R.F. millivoltmeter to the output and tune 3C16 for maximum output. Check with a wavemeter that the output is on the 473MHz required. If a Spectrum Analyser is available, alignment is, of course, somewhat quicker and easier. Spurious outputs should be at least 25dB down. The output level should be at least +5dBm.

4. V.S.B. FILTER

The complexity of the V.S.B. Filter has been kept to a minimum in order to facilitate alignment for those with limited test equipment. The group delay performance of the filter is certainly none too good, but this does not affect the picture quality seen on the screen.

It consists of three M derived pi sections with reject frequencies of 41.5MHz, 43.7MHz and 45.4MHz. Note that it is low pass and therefore removes the UPPER sideband. Since the heterodyne frequency is higher than the output frequency, (473MHz, 433.6MHz respectively) inversion takes place and it is the LOWER sideband that is truncated.

Fairly close tolerance capacitors (5%) should be used, plate ceramic being suitable.

Alignment requires a signal generator capable of covering 40-50MHz, with a source impedance of 50ohms, and an R.F. millivoltmeter with 50ohms termination. Set the signal generator to 41.5MHz and inject, say 0dBm, into the filter. Connect the R.F. millivoltmeter to the output and tune 4L1 for minimum output. Repeat at 43.7MHz and 45.4MHz, adjusting 4L2 and 4L3 for minimum respectively.

As a check, tune the generator to 39.4MHz and measure the loss which should be no more than 1-2dB.

If a Network Analyser or Polyskop etc. is available, more precise settings can of course be made. (The settings are a little interactive.)

5. U.H.F. MIXER

This unit is of the double balanced active type - this yields less loss than the diode type, and offers better linearity. Furthermore, it's cheaper!

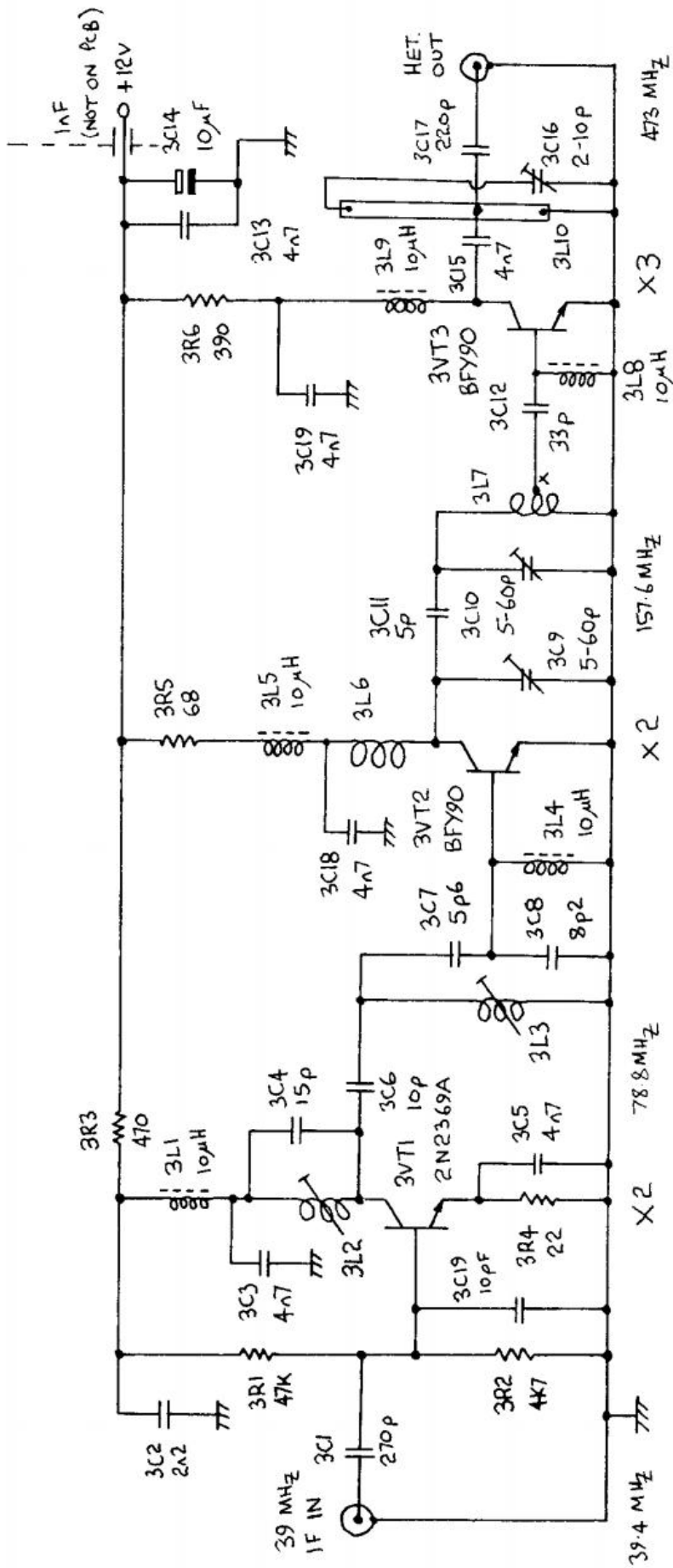

FIG. 7. 3. 12X MULTIPLIER

The input transformer 5T1 is of the same design as that used in the video modulator. The heterodyne signal of 473MHz is fed equally to the F.E.T. sources, the resulting out-of-phase heterodyne component outputs cancel in 5T2 primary - leaving (theoretically) the two in-phase sidebands. Preliminary lower sideband filtering is performed by 5L2, the output is then amplified by 5VT3 by around 12dB. Finally, the signal arrives at 5F1, the double helical filter which provides the main upper sideband rejection.

Alignment requires the use of a U.H.F. signal generator and a V.H.F. one. Alternatively, completed and working transmitter boards 1 and 3 may be used, or a combination. An R.F. millivoltmeter is needed and a sensitive wavemeter would be useful. The ideal is, of course, a Spectrum Analyser!

The first task is to adjust 5VT3 bias - to do this, turn 5RV2 to MINIMUM resistance. Apply +12V. With a voltmeter connected to 5VT3 collector and ground, adjust 5RV2 for 6V. This can be optimised for best video (differential phase and gain, etc.) when the whole transmitter is finished.

Inject around +10dBm of I.F. into the I.F. input, and around +5dBm into the heterodyne input. (More may be required initially until a rough alignment has been achieved.) Set 5RV1 to mid-travel. With the wavemeter or R.F. millivoltmeter connected to the output, tune 5C6, 5C7 and 5C17 for maximum 433.6MHz out. Slight adjustment of 5C1 and 5C2 values may improve output and the video bandwidth. 5C6 and 5C7 settings should be roughly symmetrical.

Remove the I.F. input, adjust 5RV1 for minimum 473MHz output (Carrier balance). The output should be +2dBm approximately.

6. U.H.F. PRE-AMPLIFIER.

This is a straightforward amplifier requiring only a signal generator or part completed transmitter, and an R.F. millivoltmeter or sensitive power meter for alignment. The gain of this unit when aligned is typically +15dB and will probably need backing off a little in a completed transmitter system. An output of 50-100mW with good linearity is achievable. Inject a U.H.F. signal of +5dBm of 436MHz into the input. (433.6MHz may be used, but this will give inferior results as it is not band centre.) Adjust 6C1, 6C2 and 6C4 for maximum output. Some movement of 6L6 and 6L7 may also help. Again, it must be stressed that only good 2N3866's are suitable - surplus ones invariably only operate satisfactorily at V.H.F. A current of around 40-60mA quiescent should be drawn.

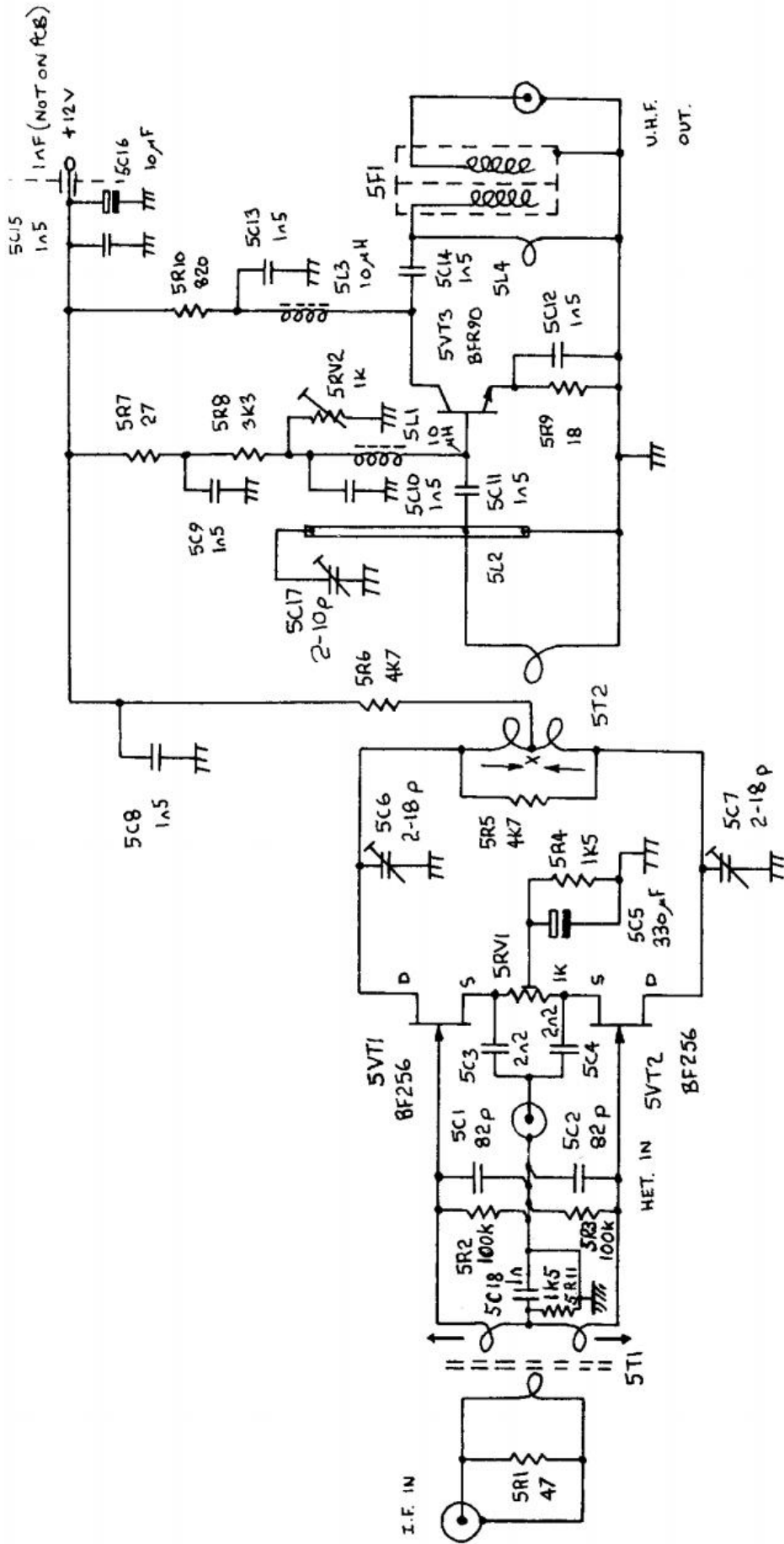

FIG. 9 5. U.H.F. MIXER.

7. POWER AMPLIFIER

This is the most expensive unit, requiring a Mullard BLX67 R.F. Power Transistor. This device is actually capable of $3\frac{1}{2}$ W C.W., but in order to achieve good IMD performance (linearity) the output is restricted to 1W peak sync. Both drive (BFW16) and output run in Class A. 7VT1, the BFW16, can be replaced by a 2N3866 without too much sacrifice of linearity. (If this is done the bias will probably need adjustment to give a collector current of around 30mA.) Some sacrifice in potential gain has been made in order to reduce the number of variables - thus easing alignment.

An R.F. power meter and U.H.F. signal generator (or part completed transmitter) are required for alignment. The first task is to adjust 7RV1 until a collector current of 200mA is reached. Proceed as per the instruction for setting up 5VT3. For peace of mind a $\frac{1}{2}$ A fuse should be included in the Supply Line. (Especially if powering from a car battery.)

Inject a 436MHz signal at the input of about +15dBm. Connect the power meter to the output. Adjust 7C2, 7C3, 7C5, 7C6 and 7C7 for maximum power out. Some size adjustment of 7L5 may be necessary. 7C2 tuning is quite sharp. If equipment is available, 7C2, 7C3 should be adjusted for best input return loss and not gain - this helps ensure stability of the amplifier chain. An SWR meter could be used to do this.

SYSTEM TESTS.

Once all the modules have been tested and aligned, the whole transmitter can be connected up. (As directed earlier.) Providing care has been taken with screening, decoupling and module alignment, the transmitter should function with no more adjustment, except perhaps backing off the linear amplifier chain gain (stagger tune). With no input, the transmitter will give about 1W C.W. when the gain is right. Upon applying a standard level black and sync. signal to the input, the power should fall to about $\frac{1}{2}$ W.

The video performance can be observed on an oscilloscope by using a diode probe circuit such as has appeared in CQTV many times and in the Radio Amateur's Handbook. For this the V.S.B. filter should be linked out to give A.M. (The simple detectors only give true demodulation for A.M. - V.S.B. requires a V.S.B. receive filter characteristic.) If test patterns such as staircase and burst are available, modulation depth, R.F. amplifier biasing/tuning etc. can be optimised. Time and patience can be a replacement for thousands of pounds worth of equipment.

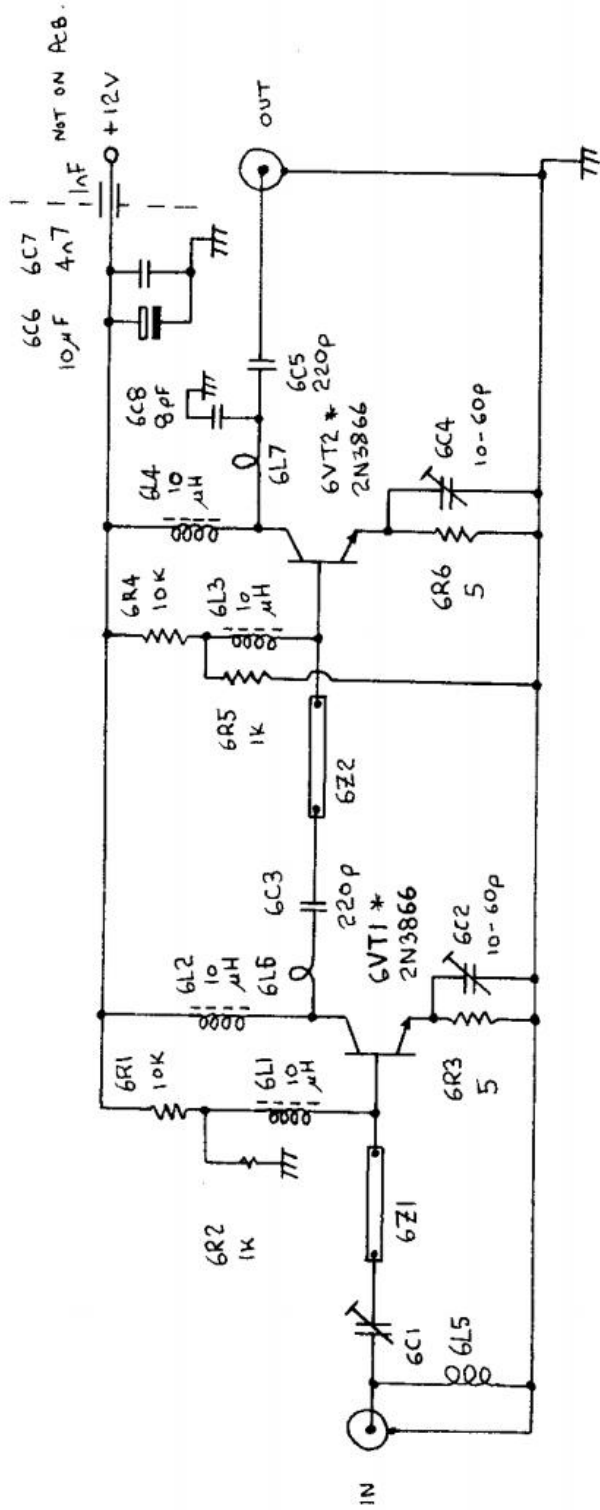

* 2N5109 OR 2N5109A ETC.
MAY BE USED WITH
SMALL ADJUSTMENTS.

FIG. 10 6. U.H.F. DRIVER.

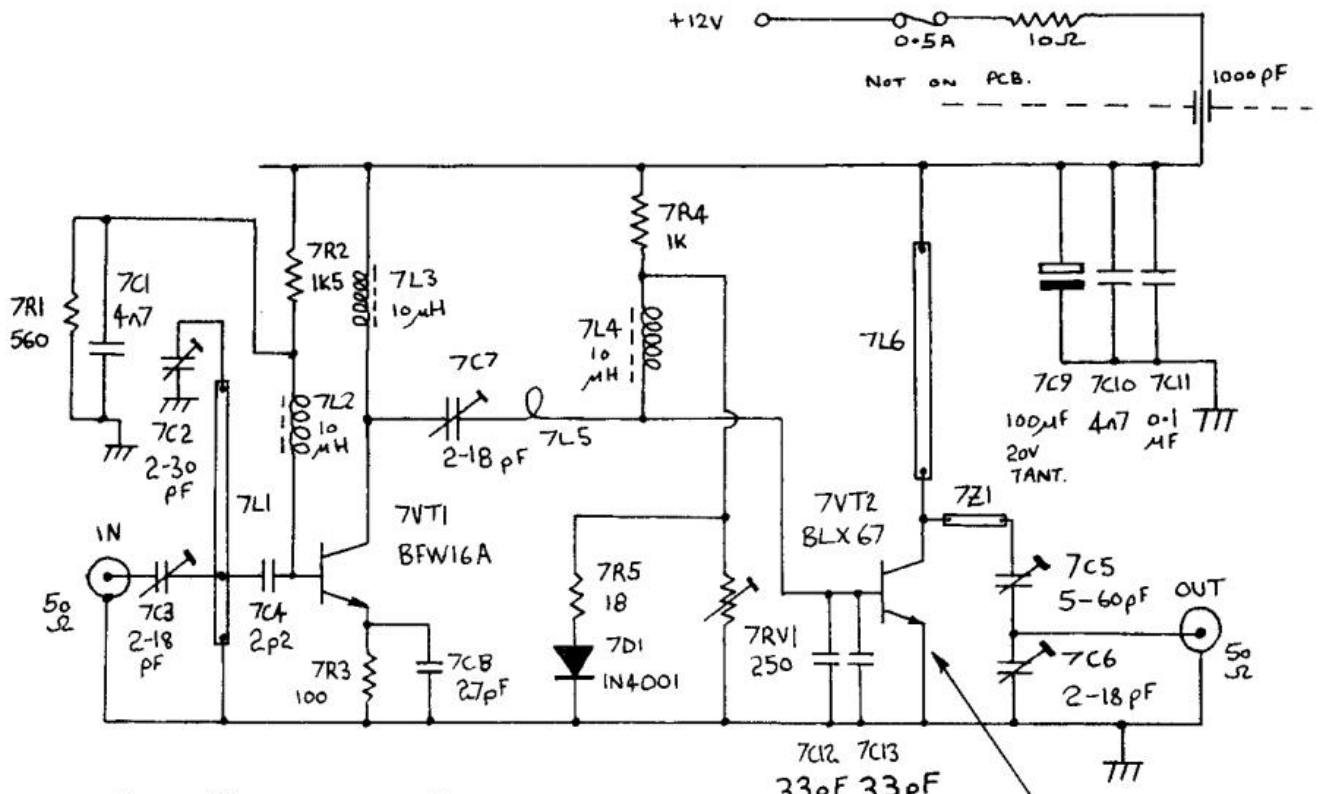

FIG. 11 7. OUTPUT STAGE.

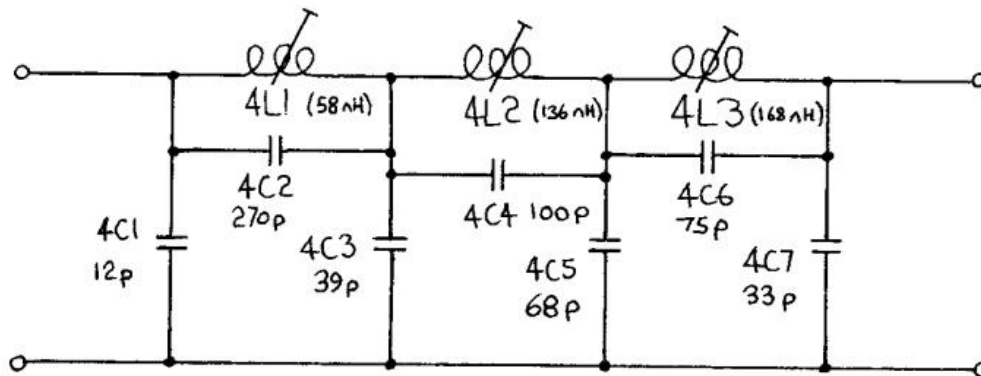
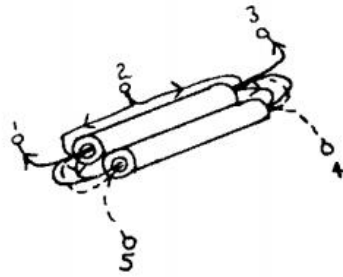

FIG. 8 4. V.S.B. FILTER.

2T1, 2T2, 5T1



— 2 TURNS C.T. } 20 SWG.
 - - - 1 TURN } EN. CU.

CORES: FX 2343

3L6, 3L7

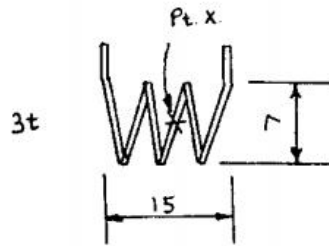

20 S.W.G. TINNED CU.
 3C12 TO Pt. X ON 3L7

5L4, 6L5

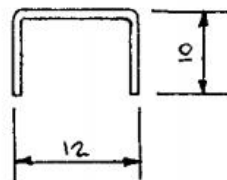

20 S.W.G. TINNED CU.

5T2

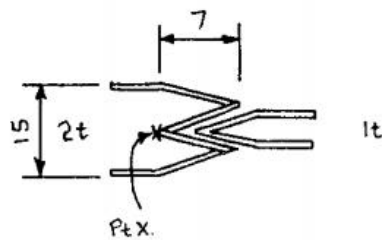

20 S.W.G. EN. CU.
 5R6 TO Pt. X.

6L6, 6L7, 7L5

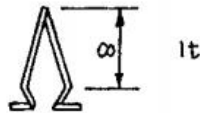

20 S.W.G. TINNED CU.

FIG. 12.

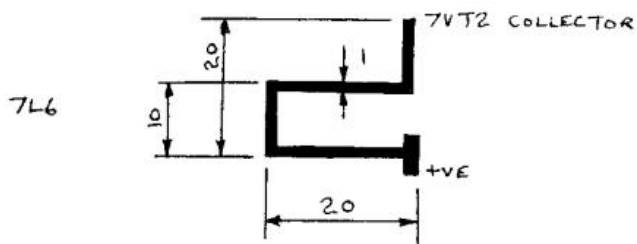
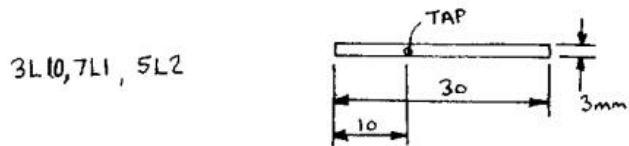
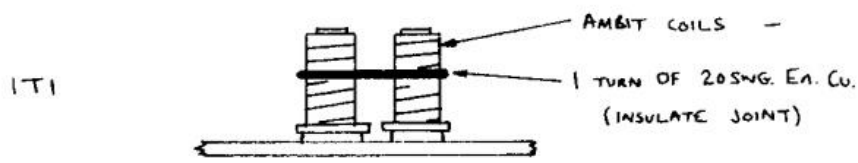

ALL ON
GLASS FIBRE $\frac{1}{16}$ "
 $E_r = 4.5$ BOARD
GROUND PLANE
ON OPPOSITE SIDE.

FIG. 13.

CONCLUSION.

Nothing in this transmitter is particularly expensive, the crystal is probably the most expensive bit, and the R.F. power transistor a closer second at around £5. The project is intended for someone with a reasonable background in R.F. construction - it cannot be described as a simple project.

Careful, methodical construction is the key coupled with no-skimping on components!

The author would recommend a valve P.A. to follow the transmitter to give more output - the linear transistors for 70-80W R.F. output are not cheap - about £70, and probably impossible for the Amateur to obtain anyway. Some commercial valve S.S.B. linears may well be suitable, if they have the bandwidth.

INDUCTOR LIST

1L1	AMBIT S18 6.5 turns
1L2	" " " "
3L2	" " " "
3L3	" " " "
3L6	
3L7	See Drawings
3L9	
4L1	AMBIT S18 1.5 turns
4L2	" " 3.5 turns
4L3	" " 3.5 turns
5L4	See Drawings
5F1	AMBIT 252MT 1001A
6L5	
6L6	
6L7	
6Z1	
6Z2	See Drawings
7L1	
7L5	
7L6	
7Z1	

TRANSFORMER LIST

1T1	(AMBIT S18 6.5 turns - 2 off)
2T1	
2T2	See Drawings
5T1	
5T2	

NOTES:

1. All drawing dimensions in mm in Fig.10 +Fig.11
2. All Ambit S18 Coils have ferrite screws

CAPACITORS: All small valued fixed capacitors should be ceramic plate.

All trimmers are film dielectric types, although Johannsen types could be of advantage on boards 5, 6 and 7.

Printed circuit boards are available for this project

FM TV TRANSMITTER

CHAPTER 5

By Trevor Brown G8CJS.

Fig.1 shows the heart of an FM television transmitter, employing a very stable free running oscillator designed to operate in the frequency range of 420 to 440MHz. The oscillator's stability comes from the design parameters and construction techniques. Using a 3 watt power transistor and considerably under-running it avoids any temperature drift. The construction is made as rigid as possible, in this way avoiding frequency changes caused by mechanical changes. A typical figure for drift is about 100KHz over several hours use.

The frequency of the oscillator is set by L1 C1 and the variable capacity diode. The modulation of the oscillator is carried out by driving this varicap diode with a video signal. The video signal is processed by the circuit shown in Fig.3. The incoming video undergoes pre-emphasis, which increases the H.F. component by 6dB's at 5MHz. This is not to C.C.I.R. standards, but is quite reasonable for amateur applications in the absence of any standards. TR1 is a dc restorer, which removes any dc level changes that often accompany video signals. TR2 and TR3 are a unity gain amplifier which present a low impedance video to the varicap diode.

The construction diagram in Fig.2 must be followed very closely. FM television has not been aimed at 70cms due to the lack of frequency space, and the fact that linearity is not a problem. By running the oscillator on 430MHz, setting up and amplification can take place using already proven experience. By moving the frequency down to 420MHz, the drive source can be used in conjunction with a tripling amplifier or varactor tripler to the 23cms band.

The standing current of the BLX67 must be kept below about 8mA in order to keep the device cool. To this end the emitter resistor is made up of a collection of resistors which may require some adjustment.

The output of the oscillator is about 50 to 80 mW and should first be followed by a linear amplifier such as the Wood & Douglas 70 LIN 3 this ensures oscillator stability. After a single stage of linear amplification, it is permissible to use non-linear amplifiers.

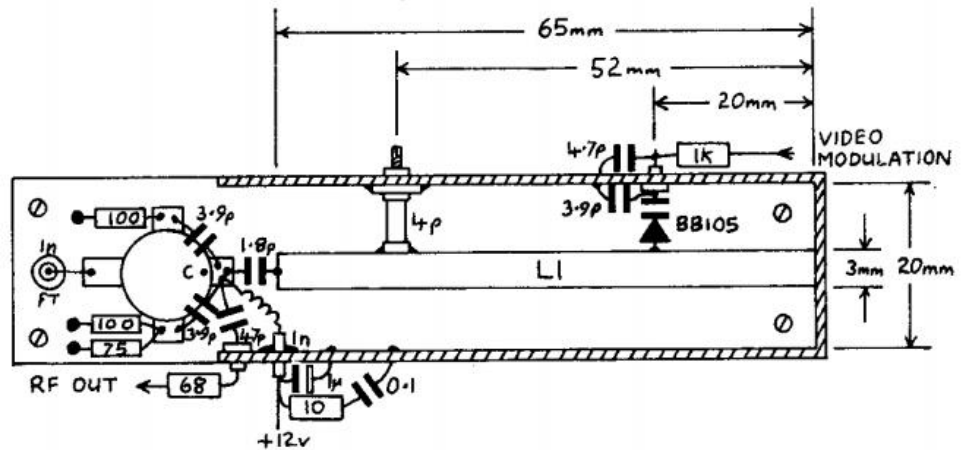
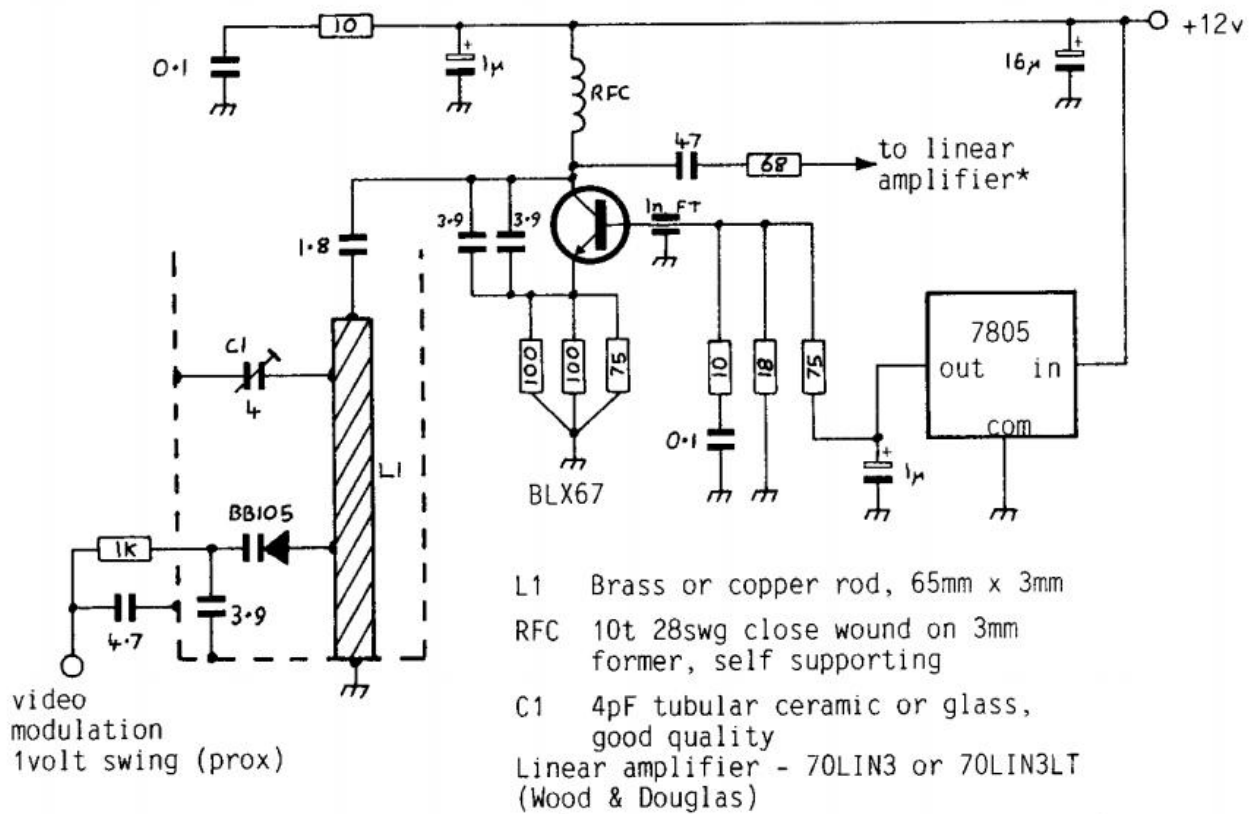

Trough made from copperclad PC board (good quality) or sheet copper or brass.
Trough height is 20mm.
Trough should be securely mounted and have good connections to ground.
BB105 diode is tipped white and may be taken from ELC1043 types of domestic TV tuners.

It is not good practice to raise the power level excessively before tripling as out of band radiation may occur.

Fig.4 shows one solution to the problem of getting from 70cms to 23cms in the form of a varactor tripler. The tripler was originally designed for 384MHz input and 1,152MHz output, the box used was an RS993, the equivalent Edystone box is a little smaller.

By using trimmers of a very small minimum capacity, it is possible to make the tripler work on 420MHz input 1,260MHz output. The BXY35A may be a little difficult to come by, but a suitable replacement is the VBC75a which is capable of 4 watts at 23cms.

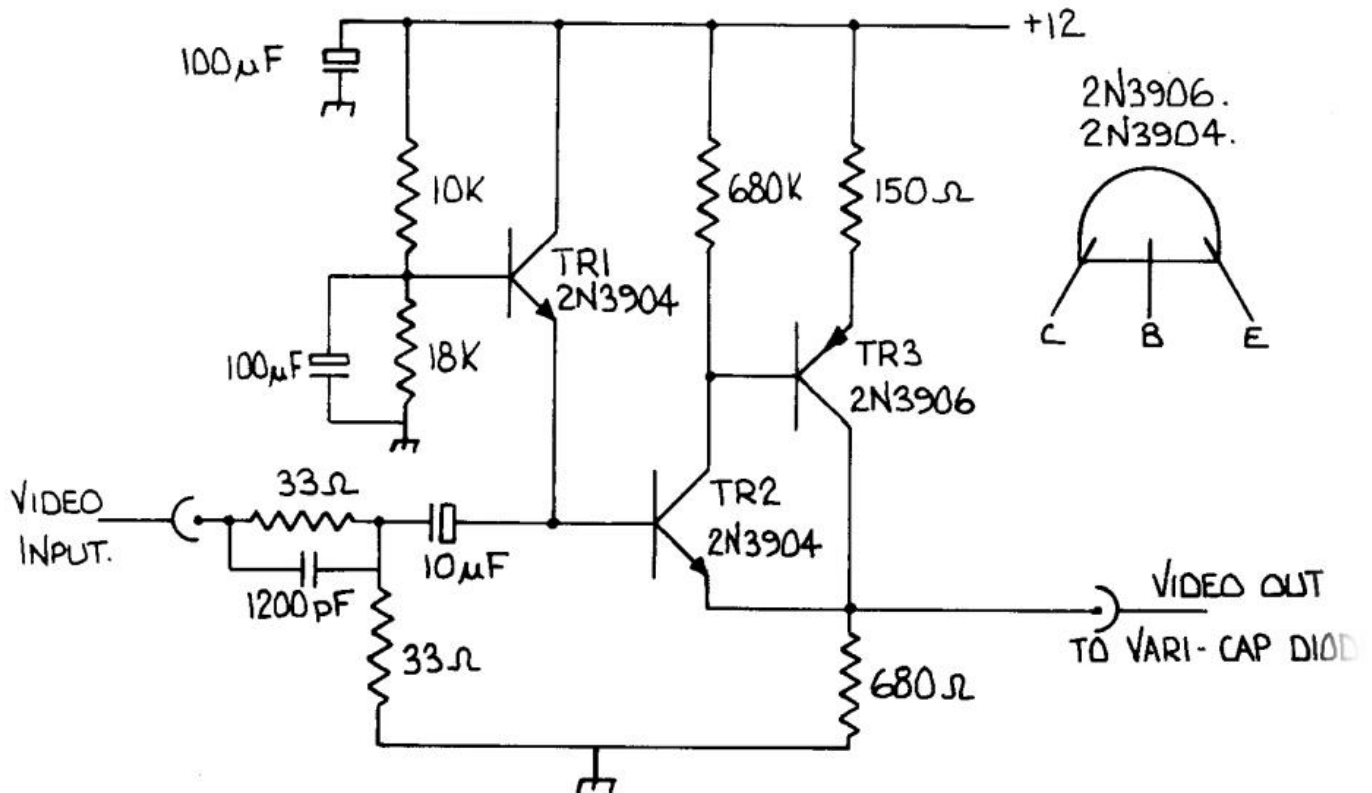
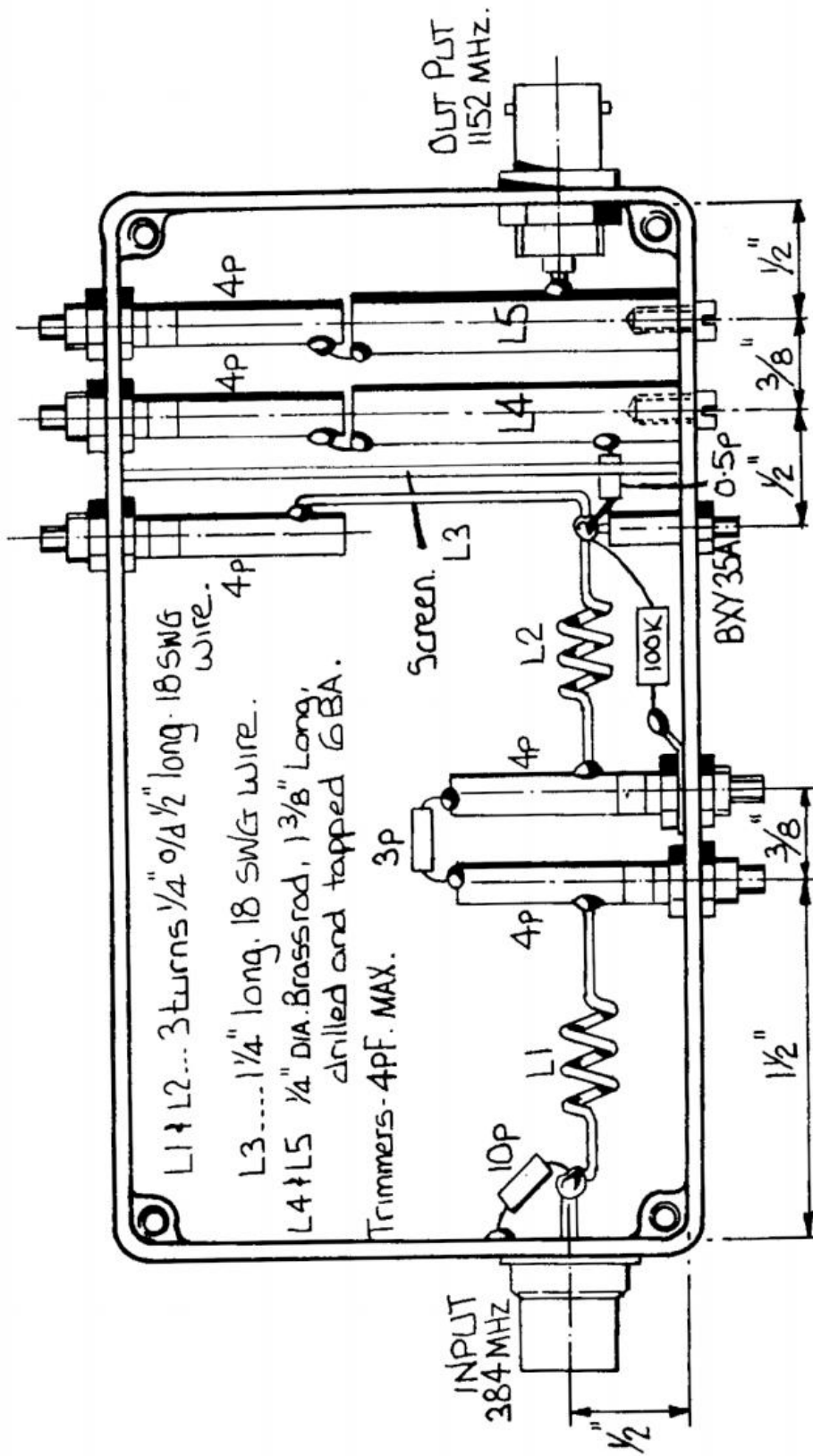

FIG. 3.



LAYOUT OF TRIPLER.

24 cms POWER AMPLIFIERS

By Marc Chamley F3YX.

During the last two to three years a range of transistors which work well up into the 4Ghz range has appeared. The most recent of these is the 2000 range which are manufactured by RTC, CTC, TRW and RCA. The range is as follows :-

2001	-	1 watt at 2Ghz
2003	-	3 watts at 2Ghz
2005	-	5 watts at 2Ghz
2010	-	10 watts at 2Ghz

In the amplifier described the Author used the 2003, which for an input drive of 500mw delivered an output of 6 watts.

In this type of transistor, the base is connected internally to the mounting stud. The input connection is made to the emitter using a line formed simply by the transistors own emitter lead, and resonated by two 6pf capacitors. The emitter choke is composed of a length of 24swg by 1½" wire bent in a ½ turn loop.

The output line is 3/8" by 11/16" and made from 24swg copper. The collector tee choke comprises of 3 turns of 24swg 1/16" dia. self supporting. The power required is 28volts and is fed into the collector choke via a feed through capacitor.

The capacitors used by the Author were Airtronic A.1. 5700.

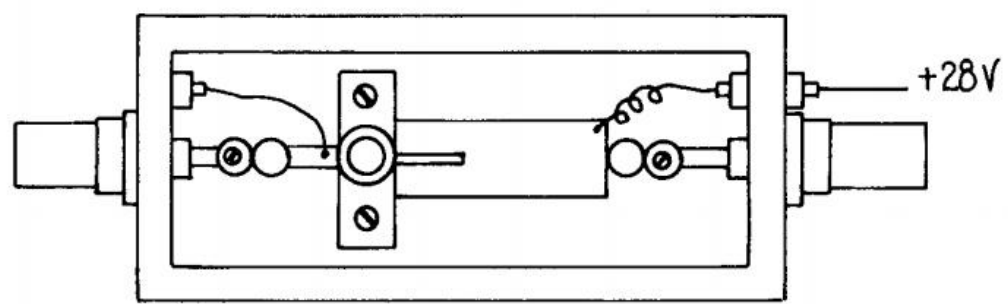
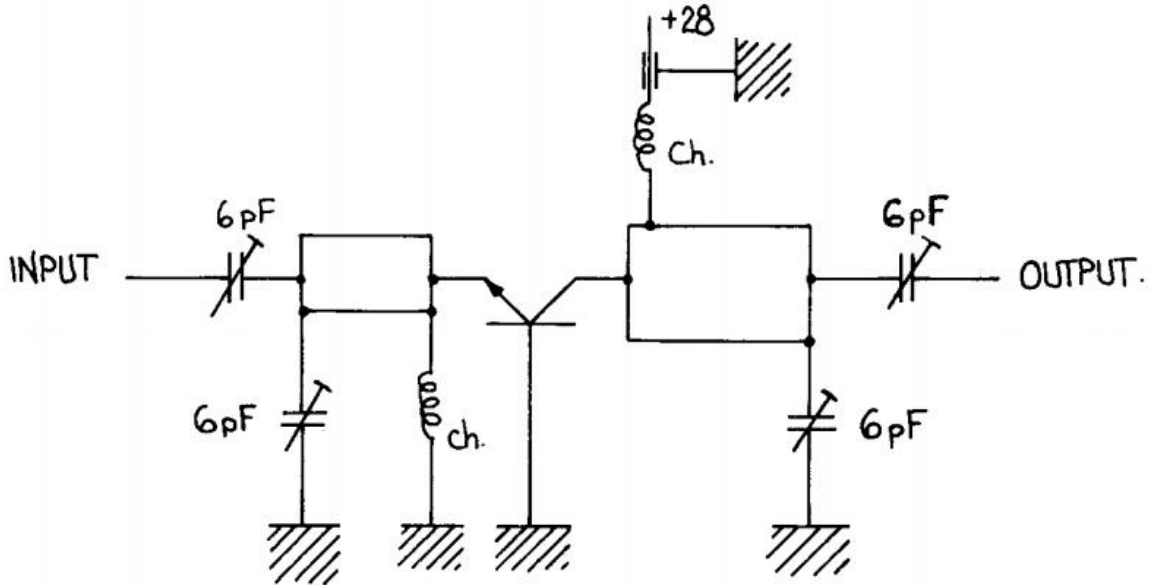
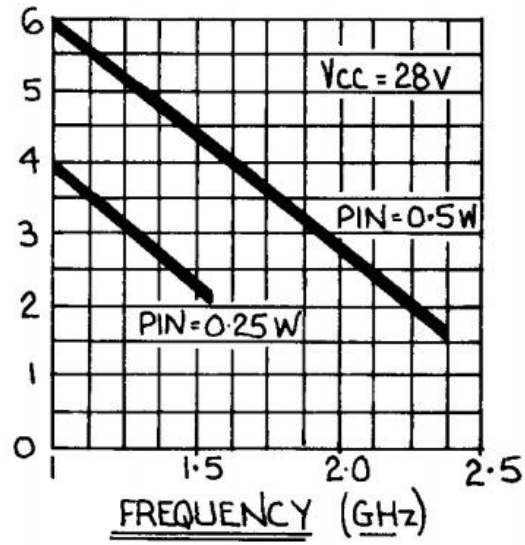

24 cms AERIALS

By M. Walters G3JVL.

INTRODUCTION

The Alford Slot antenna, which has been developed for 1.3GHz by G3JVL, is an easy means of obtaining an omni-directional radiation pattern with horizontal polarisation. The antenna has a gain which depends principally upon its length and is typically 5 to 9 dBi. This is a better performance than other simple omni-directional antennae commonly used such as halos or whips.

It is particularly suitable for a beacon or repeater antenna where an omni pattern is required with as high a gain as possible. In this application it is possible to stack two such antennae end to end (as used at the beacon GB3IOW) and nearly double the gain. With higher path losses on 23cm compared to 2m and 70cm the extra gain makes it particularly useful as a mobile antenna.

DESCRIPTION

The antenna consists of a length of slotted tubing as shown in figure 1. The width and length of the slot, the wall thickness and the diameter of tubing are all related and much experimental work has been done by G3JVL and G3YGF to evolve some working designs, details of which are given below :

<u>Tube Dimensions</u>	<u>Slot Width</u>	<u>Slot Length</u>
31.8mm OD, 20swg wall	4mm	510mm
35.8mm OD, 1.1mm wall	8mm	510mm
38.1mm OD, 16swg wall	11mm	510mm

The dimensions cover three common sizes of tubing available (copper, brass and aluminium materials are all suitable). If they are not followed exactly then some experimentation will be necessary for correct operation. In any case, it is advisable to check the field distribution in the slot as explained later.

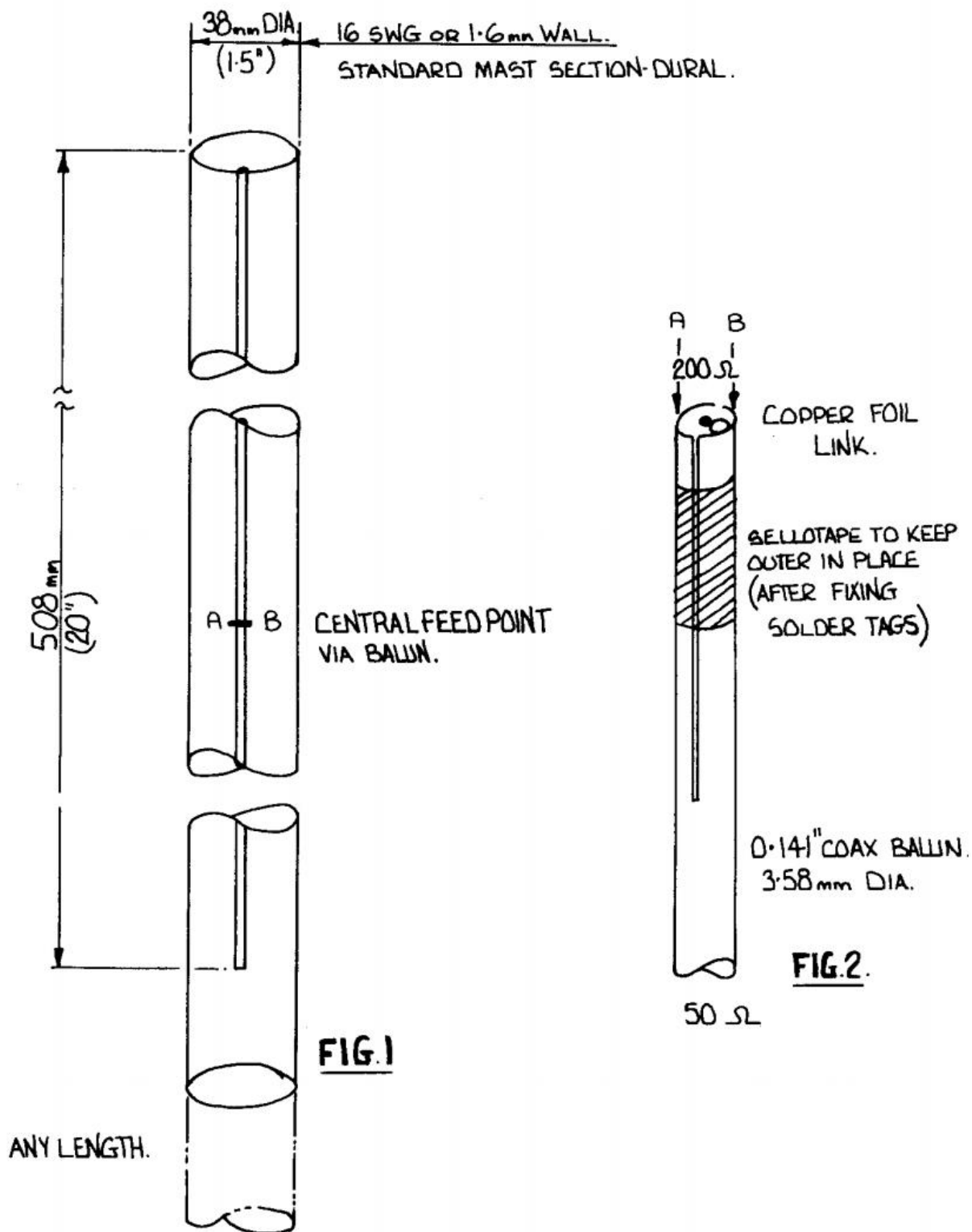

The length of tube beyond the slot is completely uncritical and the same tube could be used both as a mast and as an antenna! This includes the length of tubing above the short, so that either a simple short across the slot or a disc covering the top can be used, or the tube can be extended upwards in a similar manner to the bottom.

The feed impedance of these antennae is approximately 200 ohms. A convenient method of feeding from 50 ohm coax is to use a 4:1 balun which is fabricated from semi-rigid coax, as shown in figure 2. It consists of a piece of 0.141 inch (3.6mm) semi-rigid with two slots cut along opposite sides of the outer. The two leaves formed by the coax outer form a twin wire transmission line which is a quarter wave long, and short circuited at one end. This quarter wave resonator is excited by connecting the coax inner conductor to the end of one of the leaves. The two sides of the semi-rigid a and b are connected to the feed point of the slot (see figs 1 and 2). A convenient method of doing this is to attach small solder tags to the cable so that small screws can then be used to attach the balun assembly to the sides of the slot.

The cable should be bent round after leaving the feed point so that it sits somewhere between the back wall and the centre as it passes down the tube. The exact arrangement is uncritical so long as the cable does not come too close to the slot and upset its operation (apart from the feed point of course).

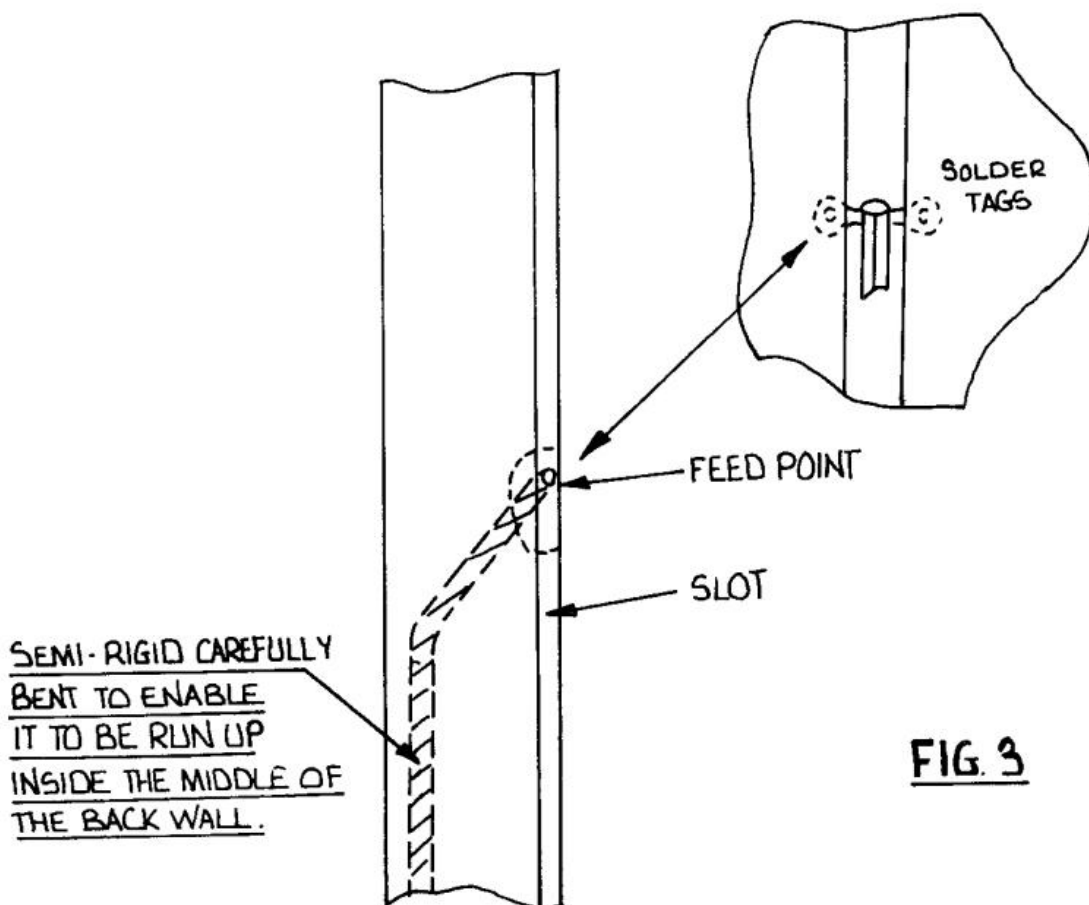

It is not necessary to connect the cable to the inside of the tube as it passes out of the bottom. However, a convenient method of mounting is to fit a shorting plate of some description across the bottom with an N-type plug or socket in it. The antenna can be mounted entirely by the N-type connector as shown in figure 4. This method is particularly convenient for mobile use where the N-type can be screwed on to a female back to back bulkhead fixed to the roof. This feedthrough in the roof can of course be used for other bands as well. Obviously many other methods of mounting are possible.

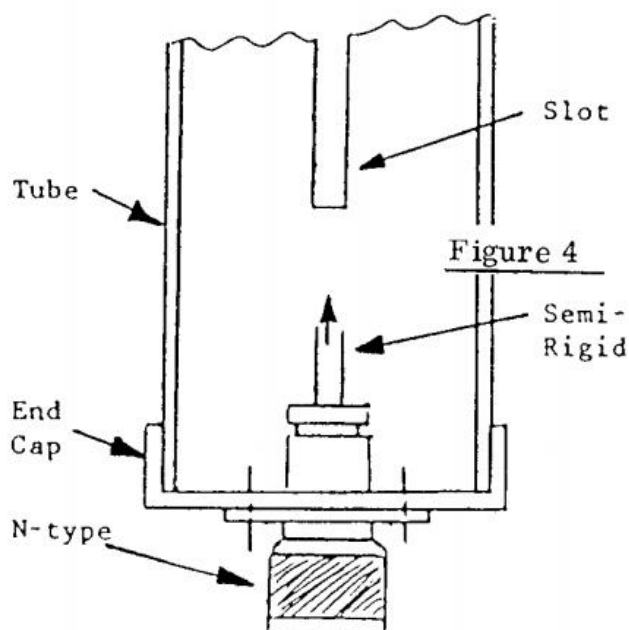

NOTES ON CONSTRUCTION.

- 1) The slot in the tubing can be cut with a hacksaw blade and filed to size. It will be necessary to drill a few holes to start off with.
- 2) If the tubing used is a plumbing material (e.g. 35mm copper central heating piping), then other fittings will be available. In particular a pipe blanking cap can be used at the base which will solder or clamp to the tube and in the centre of which an N-type connector can be mounted to bring the coax into the tube from the outside world.
- 3) The semi-rigid coax for the balun can be held in a vice and bent slightly while the cuts are made. Care should be taken not to cut into the dielectric too much. The leaves should be kept in contact with the PTFE dielectric, and not bent apart at all.

4) At the feed point two holes can be drilled and tapped to fasten the solder tags. Alternatively, the tags can be directly soldered to copper or brass tubing and the balun fastened to these later (a blow torch being needed for the first operation, a soldering iron sufficing for the second).

5) The presence of moisture on the inside of the tube will not affect its operation, apart from the balun getting wet, which will introduce a slight loss. However, water will accumulate in the tube and this is not desirable. The slot can be sealed with PTFE adhesive tape. An alternative approach is to enclose the whole assembly in a container such as a sealed length of plastic drainpipe. This method has been used successfully at GB3IOW.

OPERATION

Slot antennae are not new - a vertical half wave slot is equivalent to a horizontal half wave dipole and produces horizontal polarisation. The novel feature of the Alford is that by making the wave travel up the slot faster than light it is possible to obtain a dipole type field distribution over its length which is many times longer than the free space half wavelength value. The net gain is similar to that obtained by feeding several dipoles in phase, but is obtained without the need for a complicated phasing harness. The gain obtained is directly proportional to the length of the slot in free space in half wavelengths.

The idea that waves are travelling faster than light would at first seem impossible, but in fact it is only a standing wave pattern that appears to travel at this speed; the actual wave travels at a lower velocity than light.

The slot behaves like a transmission line shunted by inductive loops (the solid cylinder is equivalent to an infinite line of closely spaced loops). Cut off occurs when the shunt inductance resonates with the capacitance of the slot. Below the cut off frequency waves cannot propagate at all. At the cut off frequency, the velocity (and hence wavelength) is infinite. Above the cut off frequency the wavelength eventually decreases to the free space value.

In principal, any velocity factor could be used, but the higher the velocity factor (longer the slot), the more critical the dimensions. Velocity factors greater than about 10 are impractical for this reason and the normal operating range is around 5 to 15% above cut off, i.e. with velocity factors of 2 to 5. In the designs given, the velocity factor is approximately 4 and the bandwidth 100MHz at 1.3GHz. The gain achieved for the dimensions given will be about 8dBi.

The dimensions are, to a certain extent, interdependent. The

velocity factor will be increased by decreasing the tube diameter, or by increasing the slot width. The wall thickness also has an effect since it determines the capacitance across the slot so that a thinner walled material will also increase the velocity factor. Thus, if a slightly smaller diameter tube was chosen than one of the designs, then this could be compensated for by using a slightly narrower slot so that the same velocity factor is achieved. Alternatively, the length of the slot could be decreased. The antenna would then operate with a lower velocity factor, but this would give a lower gain. For 1.3GHz antenna, the tube diameter should be within the range of those given, any tube much beyond these limits will not operate correctly.

It is important that the operation is checked, particularly if any of the original design parameters are changed. This may be done by feeding the antenna with a signal at various frequencies and looking at the voltage distribution using a power meter, detector or analyser with a small probe to pick up the radiated signal. The probe should be held close to the tube, but not directly in front of the slot (hold it 20 or 30 degrees round from the edge) and moved along its length. The diode current meter described in the microwave newsletter (08/81) would be suitable for this purpose.

The balun works by taking the voltage on the unbalanced 50 ohm line and producing two output voltages relative to earth (the cable outer) which are equal to the input voltage but are 180 degrees out of phase with each other. The balanced load is connected between these two outputs and sees the difference between them, which is twice the 50 ohm voltage. Hence there is a 4:1 step up in impedance. The balun has a comparable bandwidth to the slot, about 10 to 15%. Note that the length of the cuts in the semi-rigid must be an electrical quarter wave long. Since the space between them inside is PTFE and the space around them outside is air, this gives an effective velocity factor of about 0.86. Thus the length is 0.86 times the free space quarter wavelength. If there is a significant gap between the leaves and the PTFE, then the velocity factor will be slightly higher.

SUMMARY

The antenna represents a very practical means of realising horizontal polarisation with an omni-directional pattern and high gain on 1.3GHz. The bandwidth is sufficient to cover all of the band so

that it would be suitable for any modes including TV. The circularity is very good (ratio of max to min gain) being typically 1dB. This type of antenna has also been used on other bands successfully - G3JVL has used it on 2m, 70cm and 13cm. For further details contact Mike Walters G3JVL, or Julian Gannaway G3YGF, or the RSGB Microwave Committee.

BIBLIOGRAPHY

1. Radio Communication: August 1981 page 732 (RSGB).
2. Microwave Newsletter: 02/82 and 08/81 (RSGB).

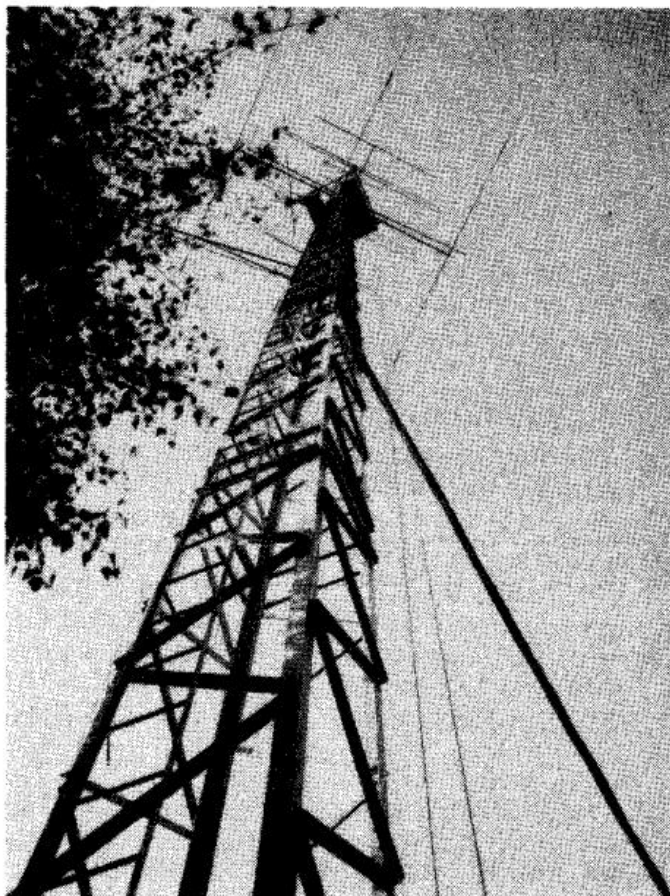

The above aerial system belongs to Marc Chamley, F5IX (Paris). Marc's 70cm TV pictures can often be received in the south of England.

10 GHz TV TRANSCIEVER

By Klaus H. Hirschelmann DJ700.

The following article describes a colour capable FM TV system for the 3cms Amateur Band. The modules are common to FM TV and could also be used on other frequency bands, for instance 13cms.

THE TRANSMITTER

The transmitter uses a simple frequency modulated oscillator and includes a variable capacity diode as a frequency control, the modulation signal is used to control this diode.

Fig.1 shows the basic version of this FM TV transmitter and illustrates the simplicity of the system.

The diode controlled X band Gunn oscillator is part of a well known Gunnplexer, made by Microwave Associates.

Pre-emphasis and De-emphasis

With frequency modulation, the signal to noise ratio deteriorates as the frequency increases. To compensate for this undesirable effect, the transmitter deviation is increased at the higher frequencies. On the receive side, this must clearly be compensated for by a corresponding filter. This way you can be sure of a linear frequency response. The concepts for this are well known, and are called pre-emphasis on the transmit side, and de-emphasis on the receive side.

The International Broadcasting Organisation C.C.I.R. has made various recommendations for the characteristics of pre-emphasis and de-emphasis filters. Fig.2 shows their recommended characteristics for both filters. Together they cause an insertion loss of 14dBs.

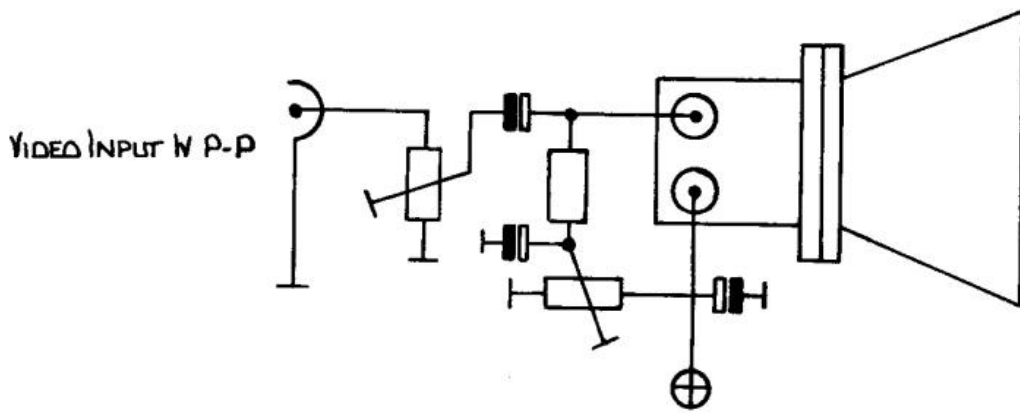

BASIC VERSION OF A FM TV-TRANSMITTER
WITH DIODE CONTROLLED OSCILLATOR.

FIG. 1

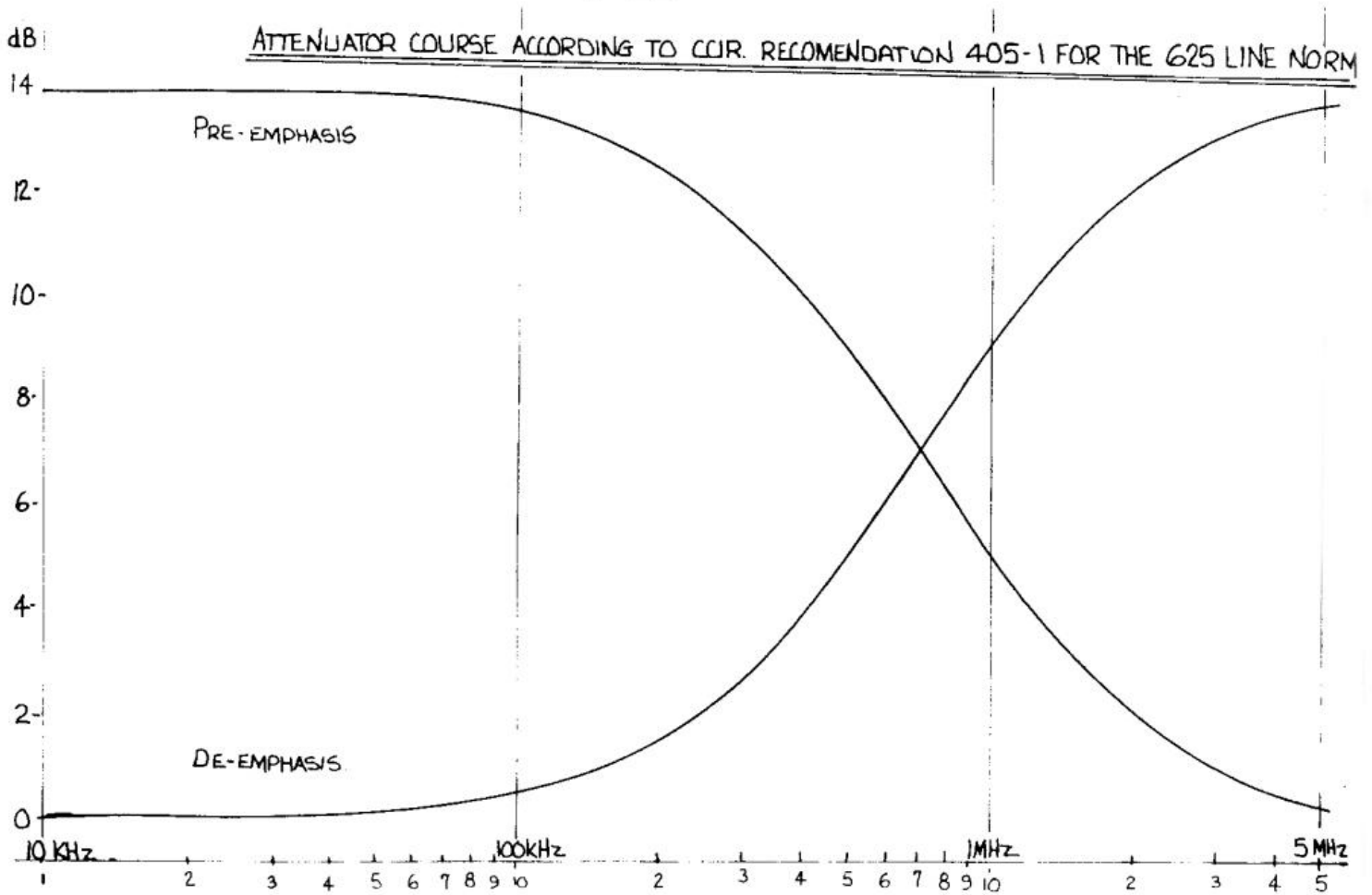

PRE - EMPHASIS.

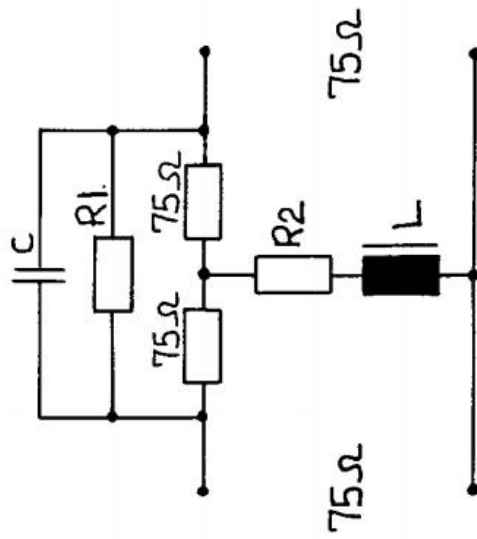

R1: 301Ω (300Ω)
R2: 18,7Ω (18Ω)
C: 1696 pF (1500+180pF)
L: 9,54 μH (10 μH)

DE - EMPHASIS.

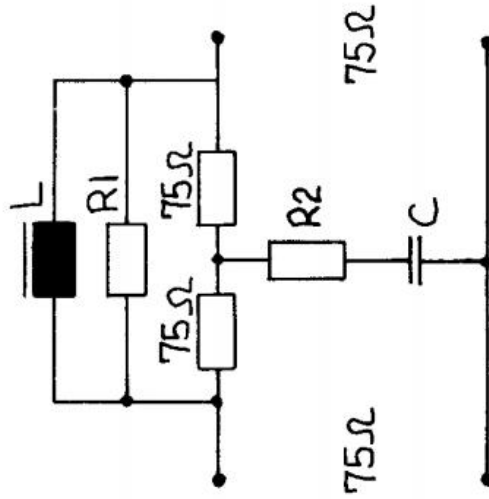

R1: 301Ω (300Ω)
R2: 19,6Ω (20Ω)
C: 5430p (4700+680pF)
L: 30,55 μH (33 μH)

FOUR POLE CONFIGURATION.

FIG.3

The effect of the filter on the transmitter side is to make the modulation swing become frequency dependent. The deviation of the system 13.5MHz peak-to-peak is only realised at the so called neutral modulating frequency of 1.5MHz. A modulation frequency of 10KHz would cause a deviation of 3.8MHz, whereas a 5MHz modulating frequency could realise a deviation of 18.25MHz peak-to-peak.

Fig.3 shows the arrangement of the filter in four pole configuration and the necessary dimensional data for the 625 line norm.

Component values shown in the first column are the exact values required, the more readily available values shown in brackets are quite adequate for amateur applications. The author's filter was, in fact, made according to the values shown in brackets. By inserting the pre-emphasis and de-emphasis filters an improvement of video related signal to noise ratio of 13dBs was achieved.

Fig.4 shows the complete video modulation set up with pre-emphasis and an additional video amplifier to make up for the insertion loss caused by the filter. The NE592N integrated circuit is used for video amplification, this allows for simple adjustment of the video level without introducing other undesirable effects.

TRANSMITTER AUDIO

For a complete TV transmission system, you will also require an audio channel. With an FM system one generally has an FM modulated subcarrier. The deviation of this audio subcarrier is 50KHz. The subcarrier frequency chosen was 5.5MHz. The reason for 5.5MHz subcarrier was that some of the more commonplace components associated with the domestic side of television could be used, i.e. filters. There is no reason why 6MHz sound could not be used in countries where 6MHz sound is the norm.

Fig.5 shows the complete audio side of the transmitter. This comprises of a modulating amplifier and limiter. A capacity modulated 5.5MHz oscillator, and amplifier with buffer stage. The subcarrier signal goes direct to the control input of the Gunnplexer. The level of the audio subcarrier should be about 30% of main carrier level.

VIDEO MODULATION AMPLIFIER WITH PRE-EMPHASIS

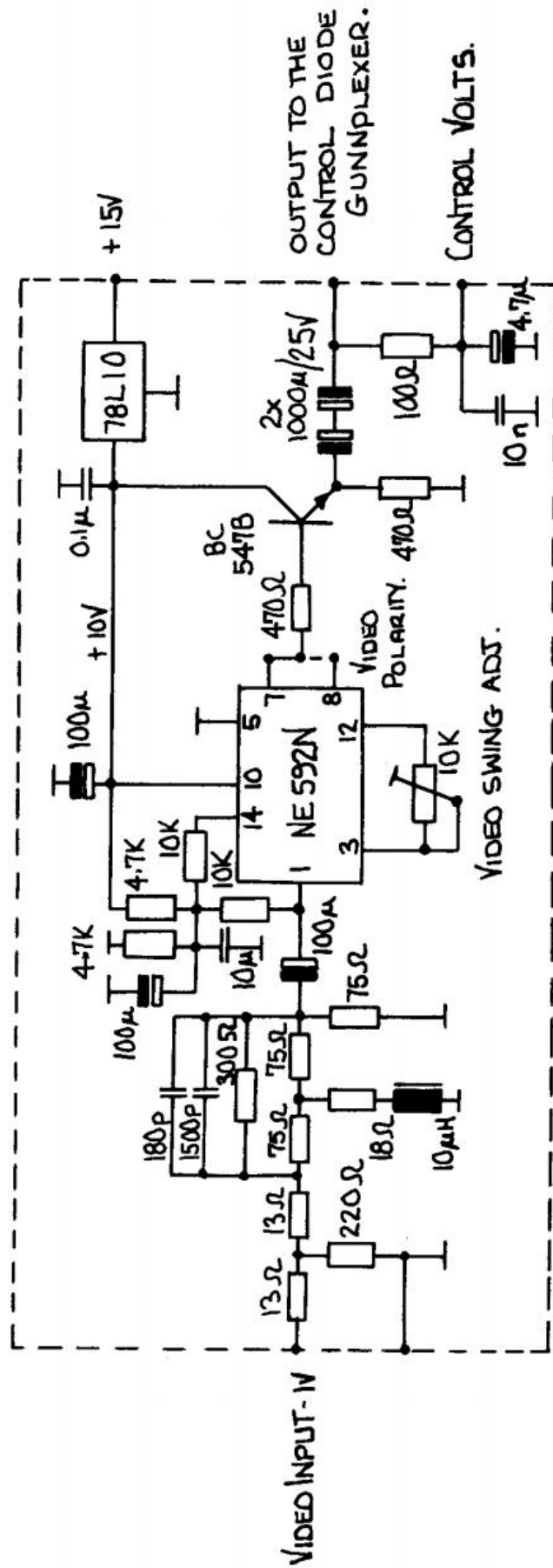
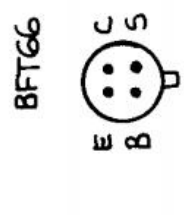
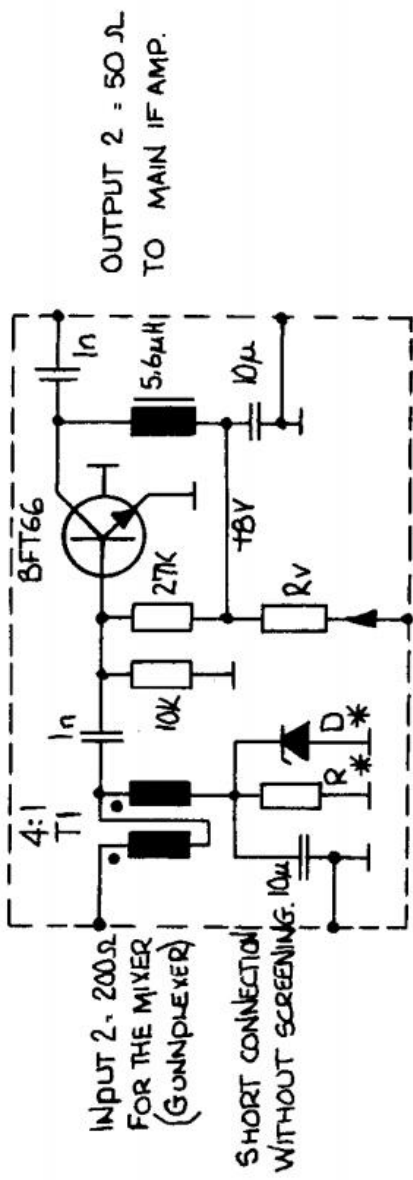

FIG. 4.

I.F. PRE AMPLIFIER



VIEW ON UNDERSIDE.

T1 = FERRITE RING TRANSFORMER
 FT 37/61 FROM 0.3 OR 0.4mm WIRE
 VARNISHED COPPER 2 x 7 TURNS

* RD - RESISTOR AND ZENER PROTECTION
 DIODES WERE SUPPLIED TOGETHER WITH
 THE GUNNPLEXER.

FIG. 6

THE RECEIVER

The IF pre-amplifier

With the exceptional requirement for as flat as possible response over the whole channel, there are no specific criteria for FM pre-amplifiers other than those which already exist for AM systems. Good signal to noise ratio and wide dynamic range such as the designs by DJ7VY which are well suited (ref 12). Some redimensioning of the RF transformers was required in order to adapt his circuits to 70MHz + 15MHz. It is very important to match the input impedance of the pre-amplifier to the impedance of the mixer stage, approximately 200ohms. To do this you can use a simple ferrite ring transformer with a ratio of 4:1. The arrangement used for the pre-amplifier is shown in Fig.6 and uses a BFT66.

The Main IF Amplifier

The main IF amplifier shown in Fig.7 is composed of three broad band amplifier stages, and a coil filter arrangement to set the pass band curve. The internationally used IF frequency of 70MHz was chosen for the IF. The filter allows the adjustment of the pass band which is between 20 and 35MHz wide. The filter arrangement and dimensioning as well as some building stages yet to be described in the demodulator, are taken from (refs. 7 and 8) they were all modified to enable construction from readily available components. The trimming of the filter turned out to be uncritical on all the examples built.

The three stage broadband amplifier with ring core couplings uses modern RF transistors and is capable of achieving a gain in the order of 40-50dBs.

The IF demodulator and video section.

The IF signal passes from the main 70MHz amplifier to the demodulator Fig.8. via the input matching pad. The signal then passes through the one transistor broad band amplifier and on to the demodulator.

The demodulator used is of the phase-locked loop type. At the input to the phase-locked loop some of the signal is rectified and brought out to a test point to enable field strength measurements to be made.

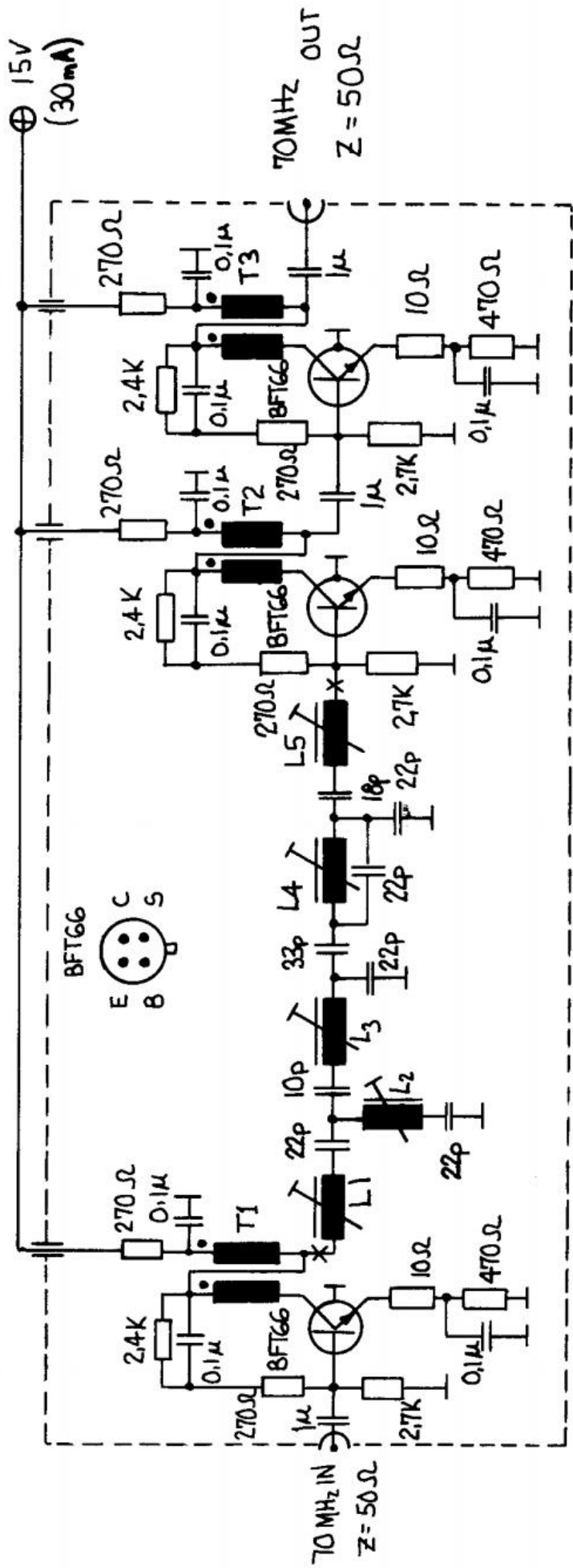

T1-T3 : 2x7 TURNS OF 0.4mm VARNISHED WIRE WOUND
 BIFILAR ON FERRITE RING CORES OF THE TYPE
 FT 37-61 (AUNIDON) OR RD N30 (SIEMENS).
 BANDWIDTH - 20-30 MHz
 : 45 dB

L1 to L5 : Body 5mm DIA. 5K5 (NEOSID) CORE K5,
 F100 WHITE 20-200 MHz
 WIRE 0.4mm VARNISHED COPPER.
 L1 : 5T (HIGH PASS.)
 L2 : 8T (LOW NOTCH.)
 L3 : 10T (MID PASS.)
 L4 : 5T (HIGH NOTCH.)
 L5 : 8T (LOW PASS.)

70 MHz IF PRE AMP

FIG. 7.

The NE564N is a very useful chip for the demodulation of broad band signals. Adjustment is very simple, the voltage controlled oscillator should be monitored via pin 11 with a frequency counter or an oscilloscope and the trimmer between pins 12 and 13 set for a frequency of 70MHz. This adjustment must be carried out without an input signal. It should be noted that we are operating the NE564N above its maximum operating frequency of 45MHz, 90% of all examples worked without any problems.

Phase-locked loop demodulators have in contrast to the more conventional demodulators certain advantages. The first being ease of construction and alignment, but the improvement of the FM threshold and an improvement of signal to noise by some 5dBs is also useful. The phase-locked loop, as its name implies, has a locking action which means it will track a drifting signal making AFC unnecessary.

The video signal passes from the demodulator through de-emphasis and on to a 5.5MHz notch filter which removes audio subcarrier patterning.

An NE592N is used to increase the level of the signal after de-emphasis. The output of the NE592N video stage has provision for switching video polarity. There is no standard for video polarity in amateur circles, remember polarity can be inverted in a mixer, depending on which side of the signal frequency the oscillator resides. It is possible to extend this polarity switch to the outside world by a small relay. The NE592N drives an emitter follower to provide standard video levels of 1 volt across a 75ohm termination. This level is set by the gain control provided on the NE592N.

Receive Audio Section.

The receiver audio section, Fig.9, uses an LSI chip TDA 1035T this considerably simplifies construction. The chip is an IF amplifier quadrature demodulator, and audio power amplifier. The power amplifier is capable of driving a loudspeaker direct.

The sound IF signal is taken off at the output of the video demodulator before de-emphasis and filtered in a 5.5MHz ceramic filter. The TDA 1035T and associated components take care of the rest providing loudspeaker or earpiece output levels. Volume control is achieved electronically by a DC voltage applied to pin 6. The chip is designed to operate with higher supply levels than the 15 volts used in this transceiver. No problems were apparent right down to supply rails of 12 volts.

The Transceiver.

By using the gunplexer and modules described here, one can make a complete 10GHz send and receive system. A small DC to DC converter is required to provide the control voltage, this is shown in Fig.11. It uses a TCA 720 to provide a stabilized power rail of 33 volts.

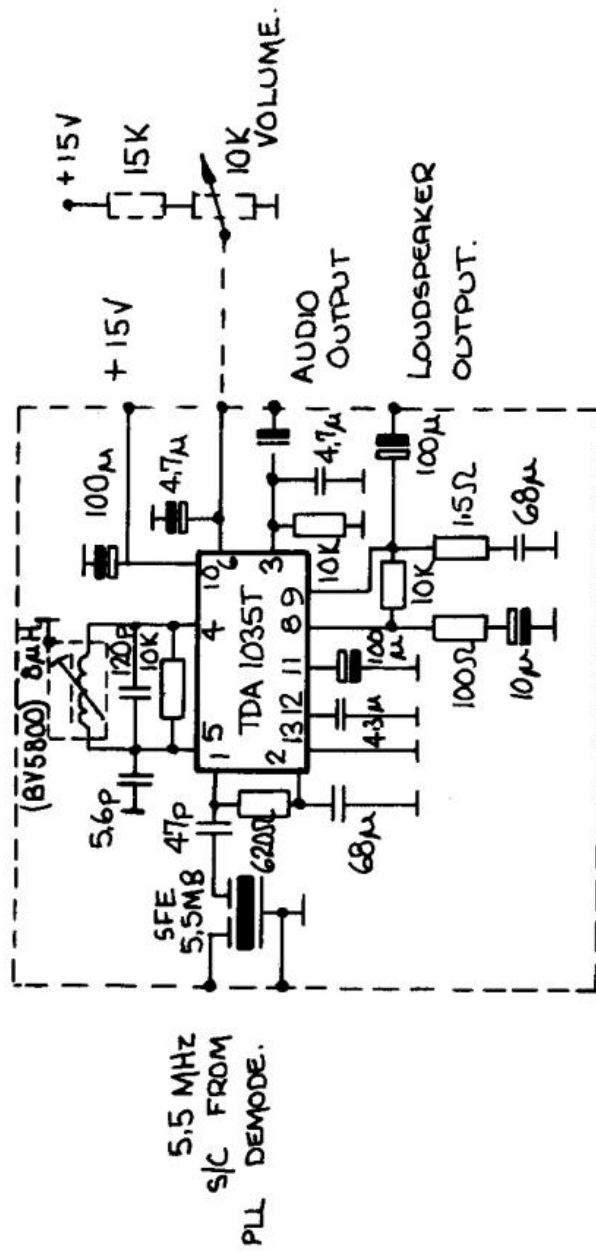

TDA 1035T 6FE 5.5 MB

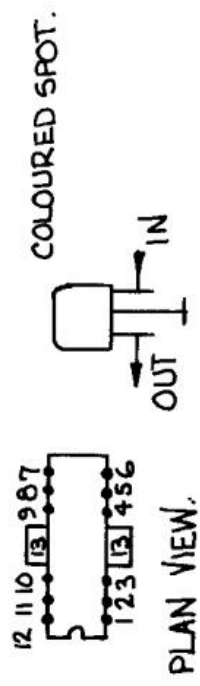

RECEIVER AUDIO SECTION

FIG. 9.

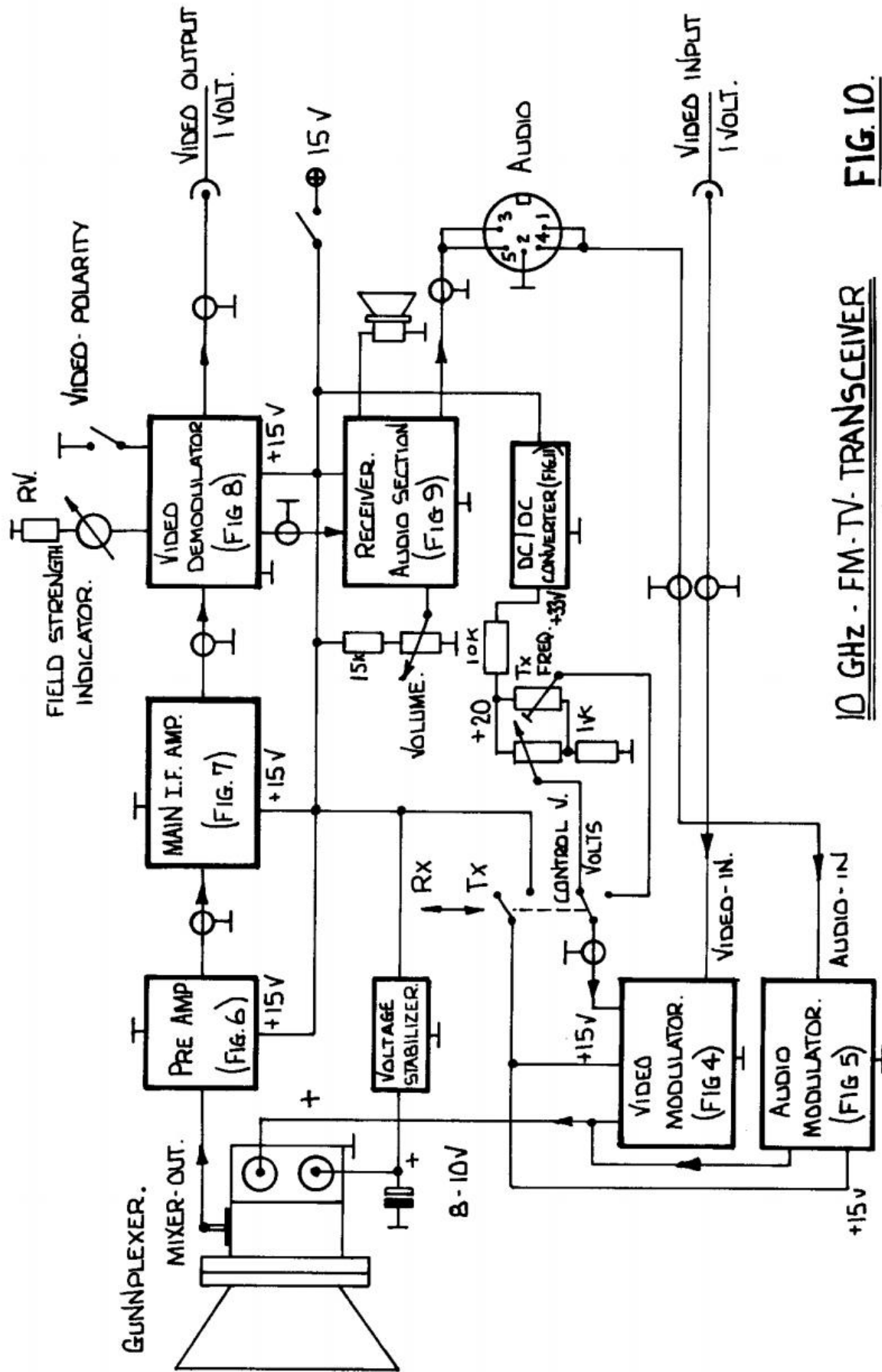

FIG. 10.

10 GHz - FM-TV - TRANSCIVER

In contrast to 10GHz telephony where duplex speech operation is possible, with television this is not the case. If both stations were to transmit at the same time, the audio subcarriers would interfere with each other. For this reason the modulators should be switched off during receive.

- 1) J.R. Fisk (W1HR), Solid-State Microwave-RF-Generators, Ham-Radio-Magazine, April 1977, S.12-22
- 2) K.H. Hirschelmann (DJ700), 10-GHz-Transceiver for Amateur Microwave Communications, Ham-Radio-Magazine, Aug 1978 S.10-15
- 3) J.R. Fish (W1HR), 10-GHz-Gunnplexer-Transceiver for Ham-Radio Magazine, Jan. 1979, S.26-43
- 4) K.H. Hirschelmann (DJ700), 10-GHz-Amateurfunkbetrieb mit dem Gunnplexer MA-87127, CQ-DL, Okt. 1977, S.383-395
- 5) Robert M. Richardson (W4UCH/2), The Gunnplexer Cookbook, Ham Radio Publishing Group, Greenville N.H., 1980.
- 6) Robert B. Cooper, S.K. Richey, A. Personal Microwave Communication System (Video-Gunnplexer) Part 1, Popular Electronics, Oct. 78, S.42-50
- 7) Satellite Television Technology (STT) Arcadio O.K., 1981 "The New Howard Terminal Manual"
- 8) Robert B. Cooper Jr., Home Reception via Satellite Radio Electronics, New York, Oct. 1979 - April 1980
- 9) H. Venhaus (DC6MR), FM-ATV, TV-AMATEUR, Heft 43/1981 S.14-21.
- 10) Datenbucher von VALVO-SIGNETICS und INTERMETALL
- 11) H.J. Griem (DJ1SL), Vorzuge und Nachteile verschiedener Sendeararten im Amateur-Funkverkehr, UKW-Berichte 1/1967 S.28-44
- 12) M. Martin (DJ7VY), Neuartiger Vorver-starter fur 145-MHz- und 435-MHz-Empfanger, UKW-Berichte, 4/1977, S.194-200
- 13) European Broadcasting Union, Brussel, 1976, Techn. 3220-E Satellite broadcasting, Design and planning of 12.6GHz systems.

The Author intends to make printed circuit boards available for this project, when that happens, they will be available through "B.A.T.C. Member's Services" along with any of the specialised components required.

The Gunnplexer is a ready built unit and is available direct from Microwave Associates of Dunstable.



SIRKIT PROJECTS

"BENBOW", WIDECROFT ROAD, IVER, BUCKS.

Tel. IVER
(0753) 651652

THE G8LES 70CM ATV SYSTEM

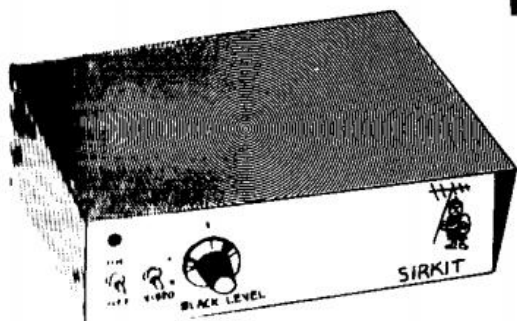

10 WATT PLUS PEAK SYNC TRANSMITTER £113.50p.
(Built and tested)

IN KIT FORM WITH BOX £ 88.50p

UP-CONVERTER - BASIC KIT - BOARD AND COMPONENTS £19.50p.

ADD-ON KIT TO USE WITH TX AS TRANSCEIVER
i.e. VISION SNIFFING (VIDEO), SWR DETECTION,
ELECTRONIC SWITCHING. NEEDS NO RELAY. £7.50p.

BASIC UP-CONVERTER BOARD BUILT £28.50p.

FULL TRANSCEIVER IN KIT FORM
(OUT WITH PA BUILT AND FULLY PREPARED BOX) £112.50p.

FULL TRANSCEIVER - BUILT AND TESTED £149.00p.

Carriage and packing on Transmitter or Transceiver
by Securicor. £5.00

12" BLACK-WHITE PORTABLE MAIN/BATTERY TELEVISION
ADAPTED TO GIVE VIDEO AND AUDIO IN AND OUT. £65.00
(This item only to special order for collecting customer)

Prices subject to alteration.

ENQUIRE FOR DETAILS OF NEW PROJECTS IN PIPE-LINE

MIKE SANDERS G8LES

JOHN BETTS G4HMG

MARK JOHNSON G8ZRT

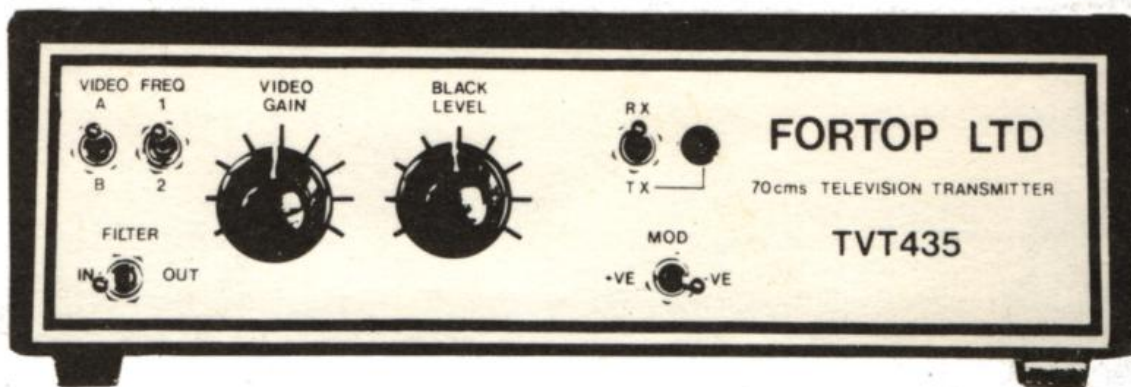

THE TVT 435 AMATEUR TV TRANSMITTER IS BASED ON OUR HIGHLY SUCCESSFUL TVT 432 TV TX UNIT BUT INCORPORATES ADDITIONAL FEATURES FOR THE SERIOUS ATV ENTHUSIAST. SWITCHES CONTROL THE CHOICE OF TWO VIDEO INPUTS, TWO VIDEO CARRIER FREQUENCIES, INSERTION OF A VIDEO BANDWIDTH LIMITING FILTER, POSITIVE OR NEGATIVE MODULATION SENSE AND POWER ON-OFF. VIDEO GAIN AND BLACK LEVEL CONTROLS ALLOW PRECISE ADJUSTMENT OF THE TRANSMITTED VIDEO SIGNAL AND OUR SYNC PULSE CLAMP CIRCUIT (WHICH WE DEVELOPED FOR THE TVT 432 UNIT) ENSURES MAXIMUM RF OUTPUT ON THE SYNC PULSE TIPS. THE OUTPUT FROM THE TRANSMITTER IS SPECTRALLY VERY CLEAN WITH VERY LOW LEVEL OF OSCILLATOR OR HARMONIC FEEDTHROUGH WITH NO VIDEO BUZZ ON YOUR 2 METRE TALKBACK CHANNEL OR BREAKTHROUGH ON TO BROADCAST TV CHANNELS. THE TVT 435 IS HIGHLY COMPACT AND OFFERS AN EXCEPTIONALLY HIGH STANDARD OF PERFORMANCE AND FACILITIES

- * 15 WATTS PSP MIN OUTPUT
- * BANDWIDTH LIMITING FILTER
- * SYNC PULSE CLAMP
- * AERIAL CHANGEOVER FOR RX CONVERTER BUILT IN
- * DUAL FREQUENCY OPERATION USING PLUG IN CRYSTALS
- * 12-13.5v @ 3.5A SUPPLY

THE TVC 435/40 AMATEUR TV RECEIVE CONVERTER WILL ALLOW USE OF ANY STANDARD UHF TV SET FOR THE RECEPTION OF 70CMS ATV SIGNALS. TWO LOW NOISE RF STAGES GREATLY INCREASE RECEIVER SENSITIVITY AND A HI-Q OUTPUT FILTER REMOVES SPURIOUS RESPONSES FROM BROADCAST TV STATIONS. USING THE TVC 435/40 ATV UP CONVERTER IS PROBABLY THE EASIEST WAY TO GET TOGETHER A HIGH PERFORMANCE ATV RECEIVING SYSTEM.

A TRANSCEIVER VERSION OF THE TVT 435 TV TRANSMITTER, DESIGNATED TVT 435/R, IS AVAILABLE COMBINING BOTH OF THE ABOVE UNITS.

THE TVD 100 VIDEO DEMODULATOR IS INTENDED FOR DEMODULATION OF TRANSMITTED ATV SIGNALS AND OBSERVATION OF THAT SIGNAL ON EITHER AN OSCILLOSCOPE OR VIDEO MONITOR. A SPECIAL FEATURE OF THE UNIT IS THE DC COUPLED AMPLIFIER WHICH ENABLES PEAK SYNC POWER TO BE MEASURED WHEN USED WITH A SCOPE.

24CMS FM AMATEUR TV.

WORK IS IN HAND ON A 24CMS ATV TRANSMITTER AND RECEIVER UNIT DETAILS OF WHICH SHOULD BE AVAILABLE BY THE TIME THIS HANDBOOK IS PUBLISHED. FOR DETAILS OF THESE AND ALL OTHER PRODUCTS WRITE OR RING,

FORTOP LTD, 13 COTEHILL ROAD, WERRINGTON, STOKE ON TRENT, STAFFS.
TEL ASH BANK (078 130) 2607.