

CPU Section

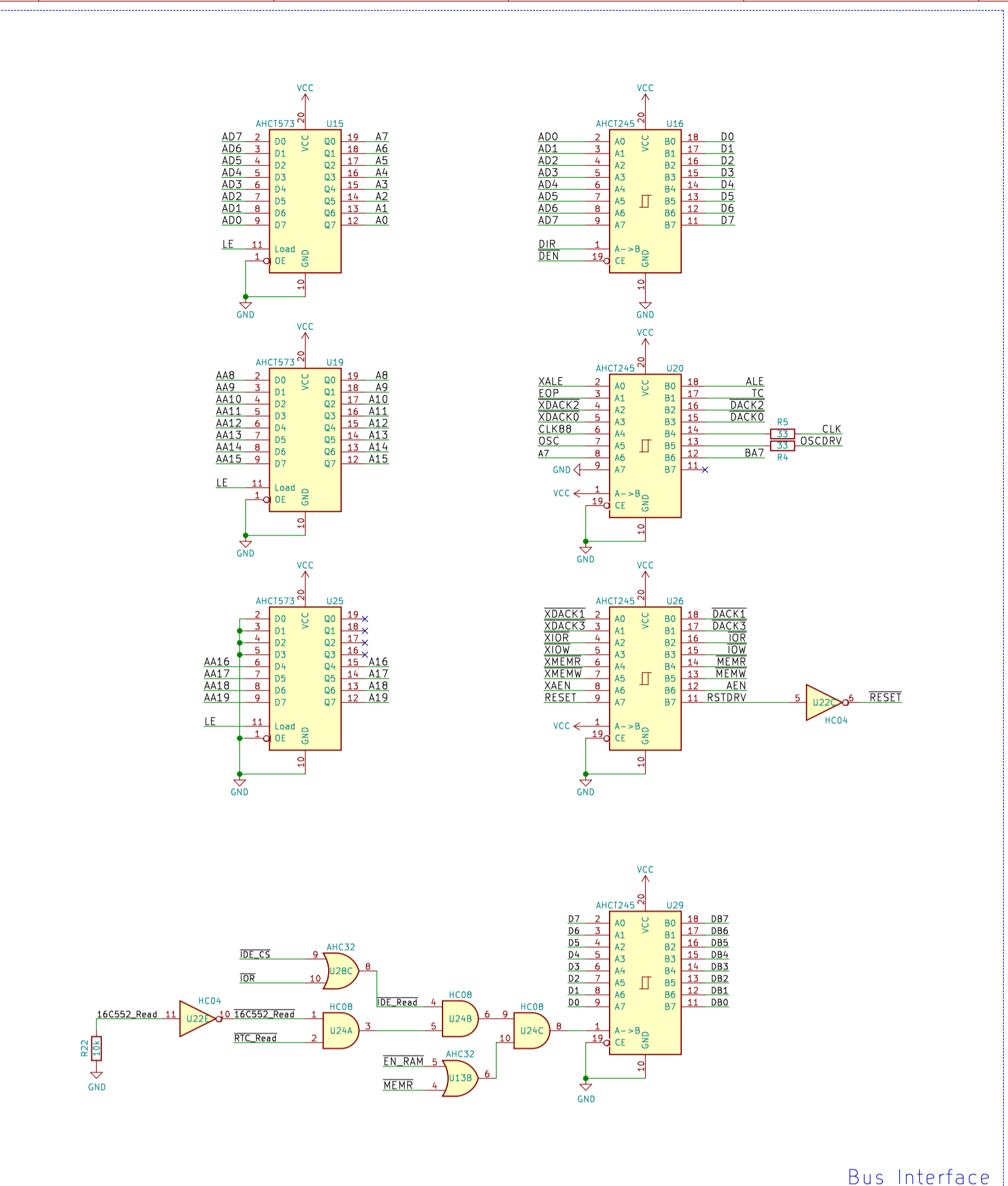

Bus Interface

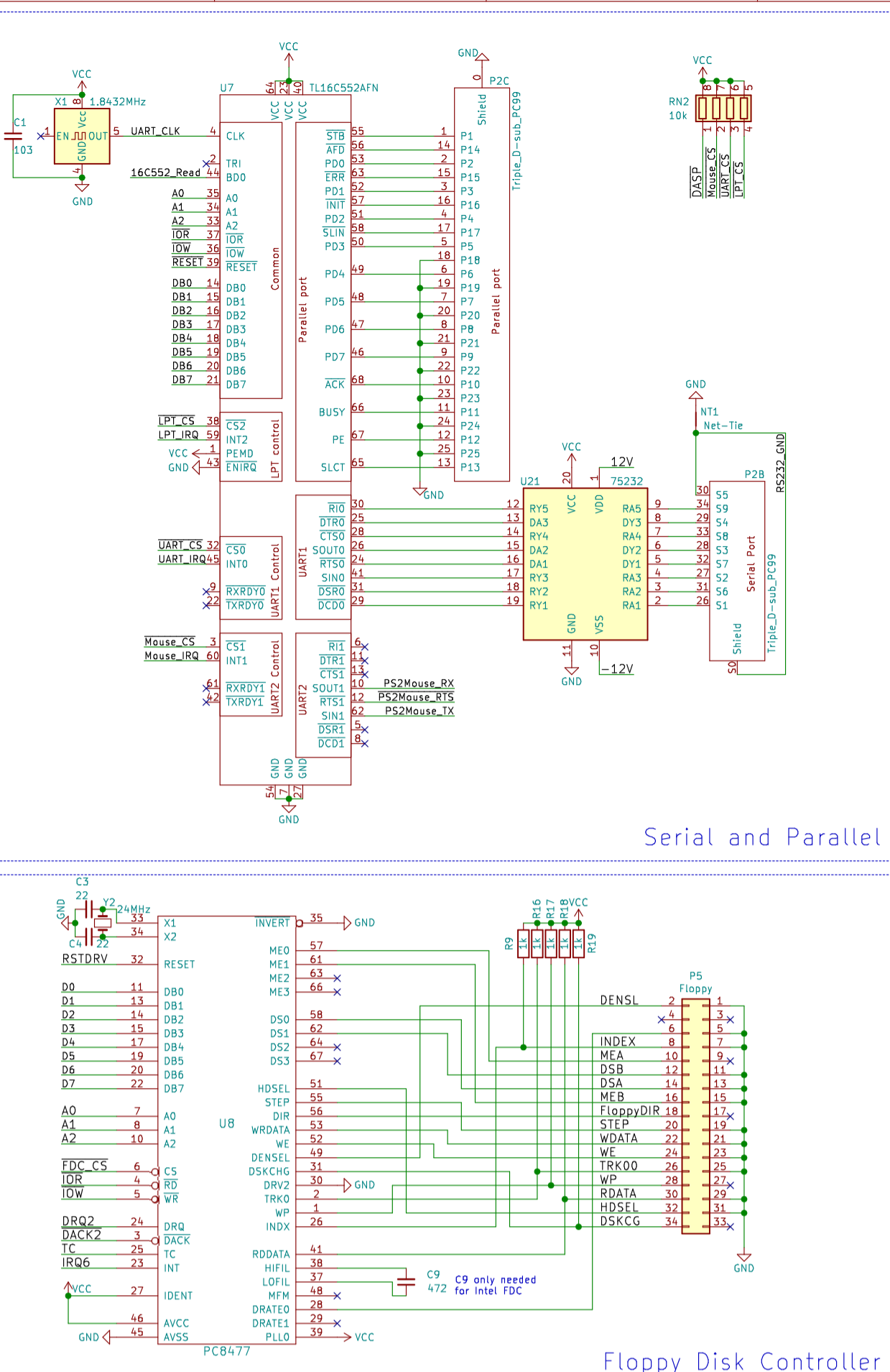

Floppy Disk Controller

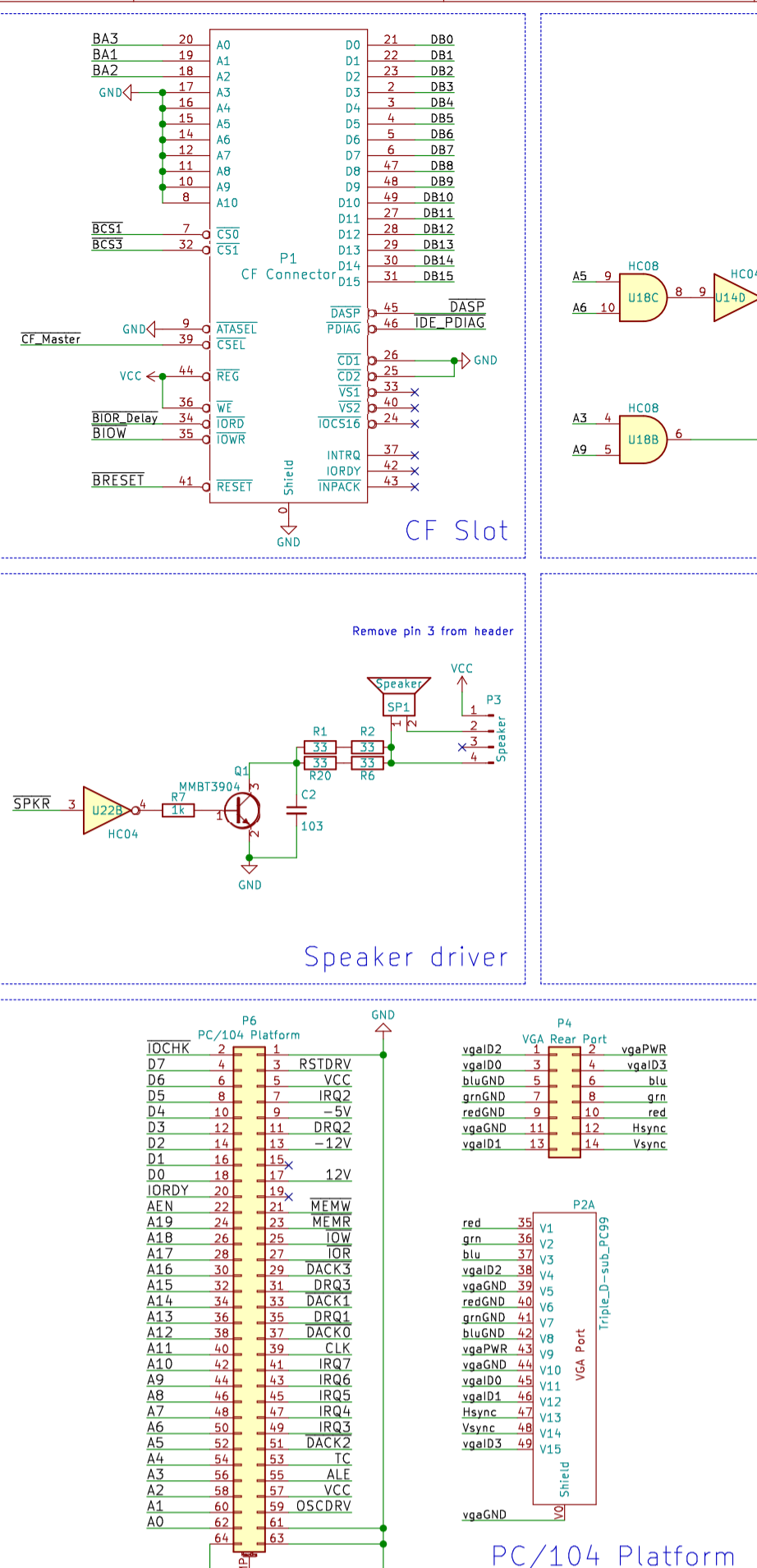

PC/104 Platform

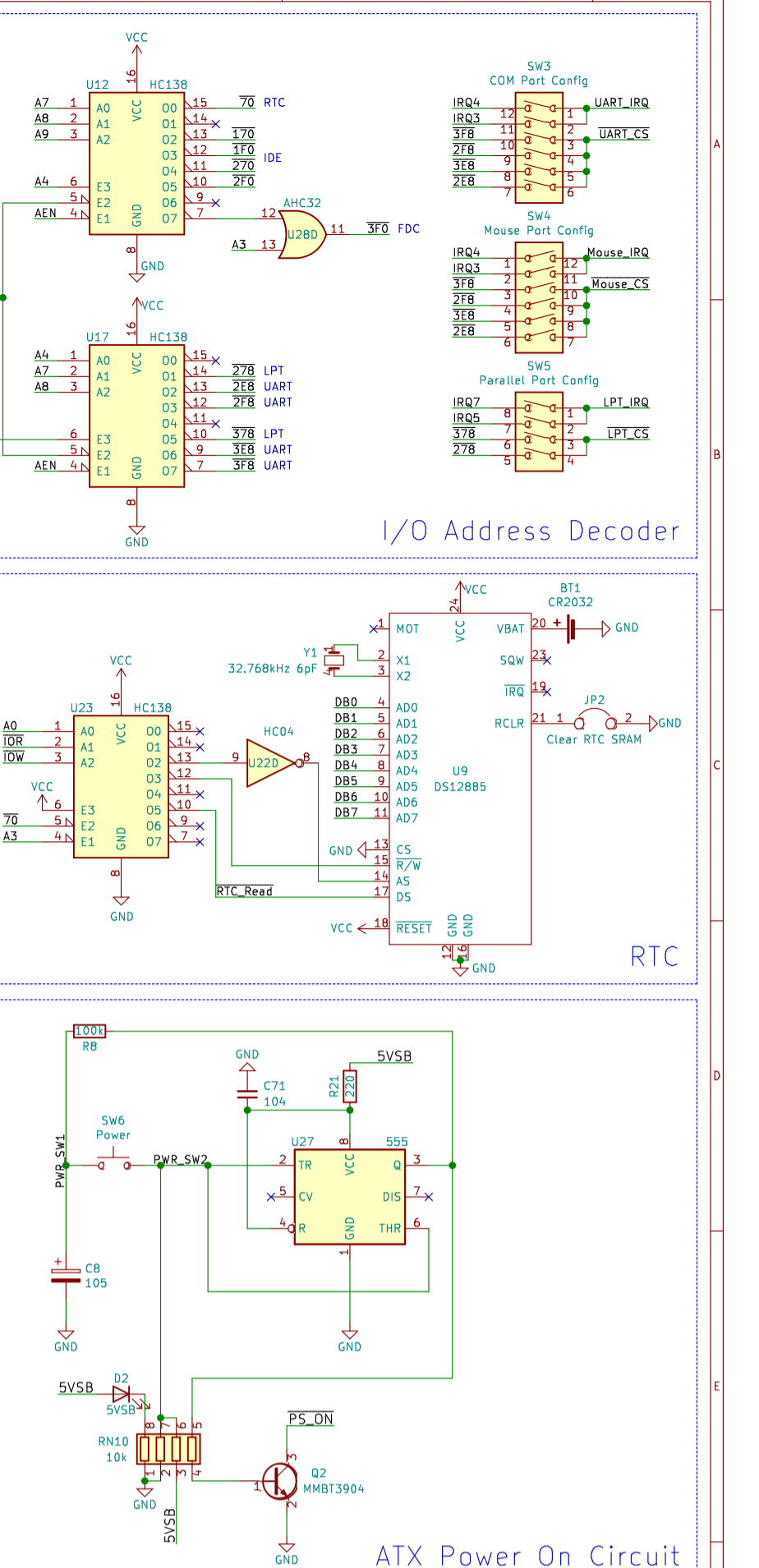

ATX Power On Circuit

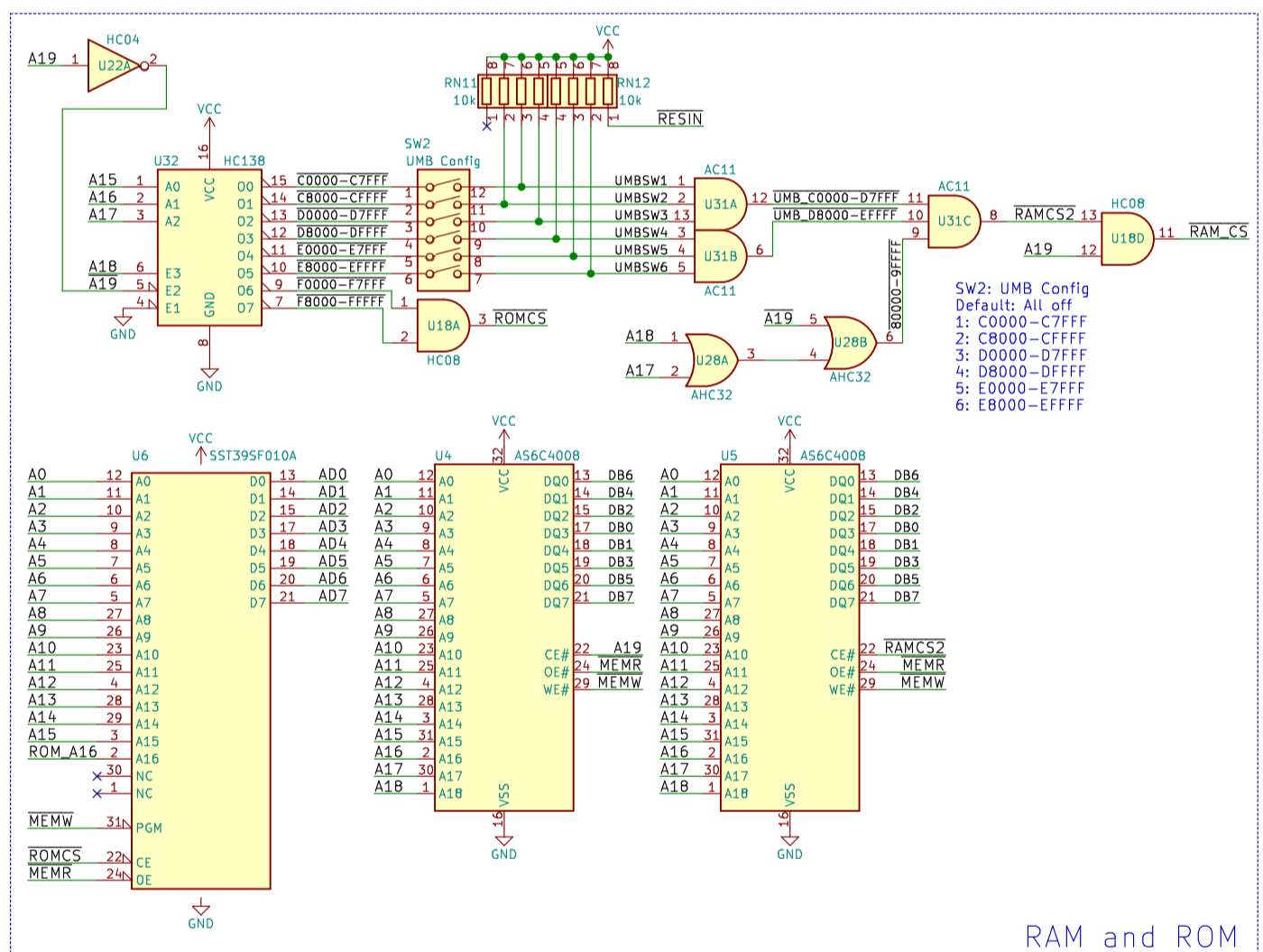

RAM and ROM

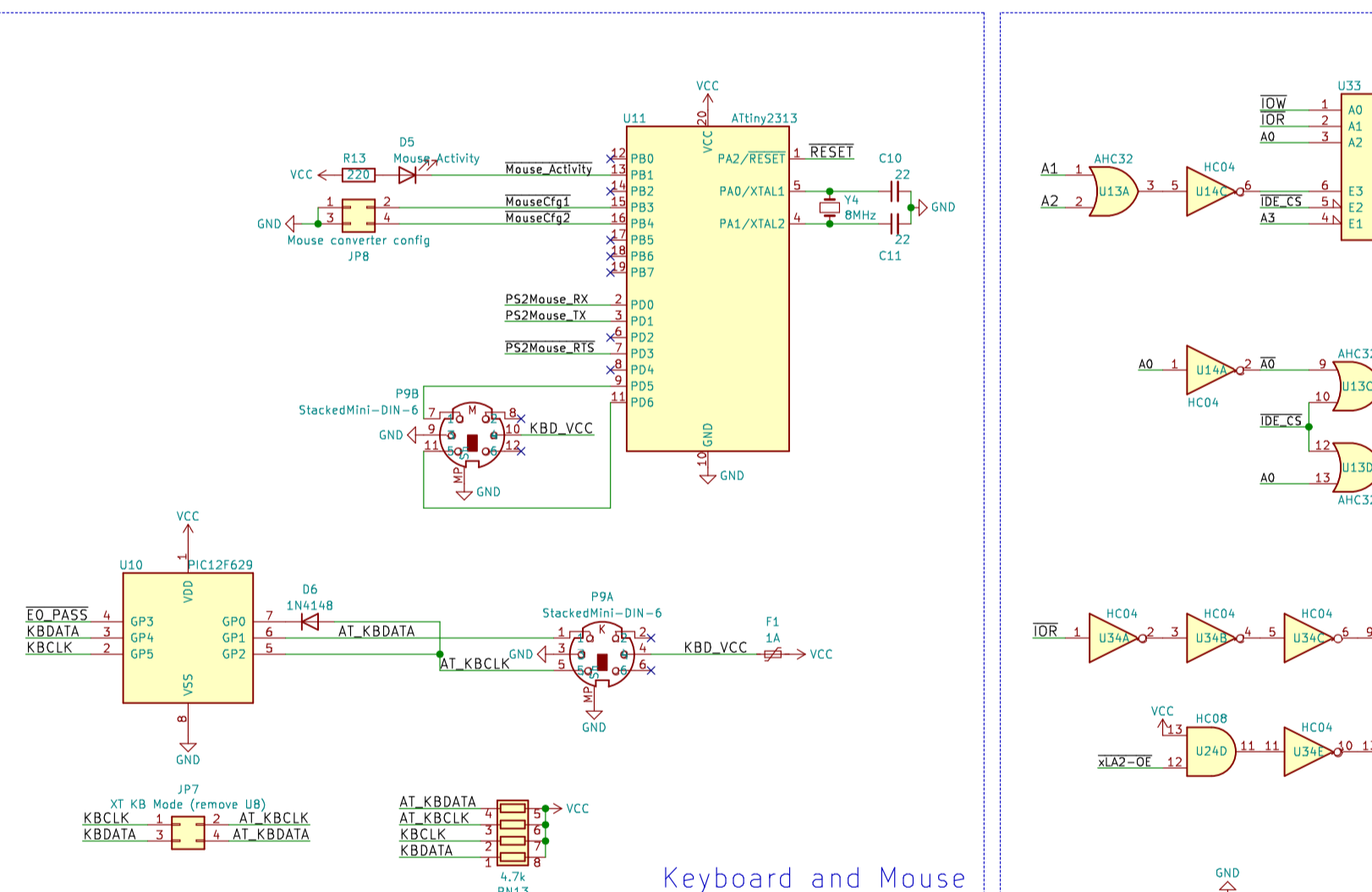

Keyboard and Mouse

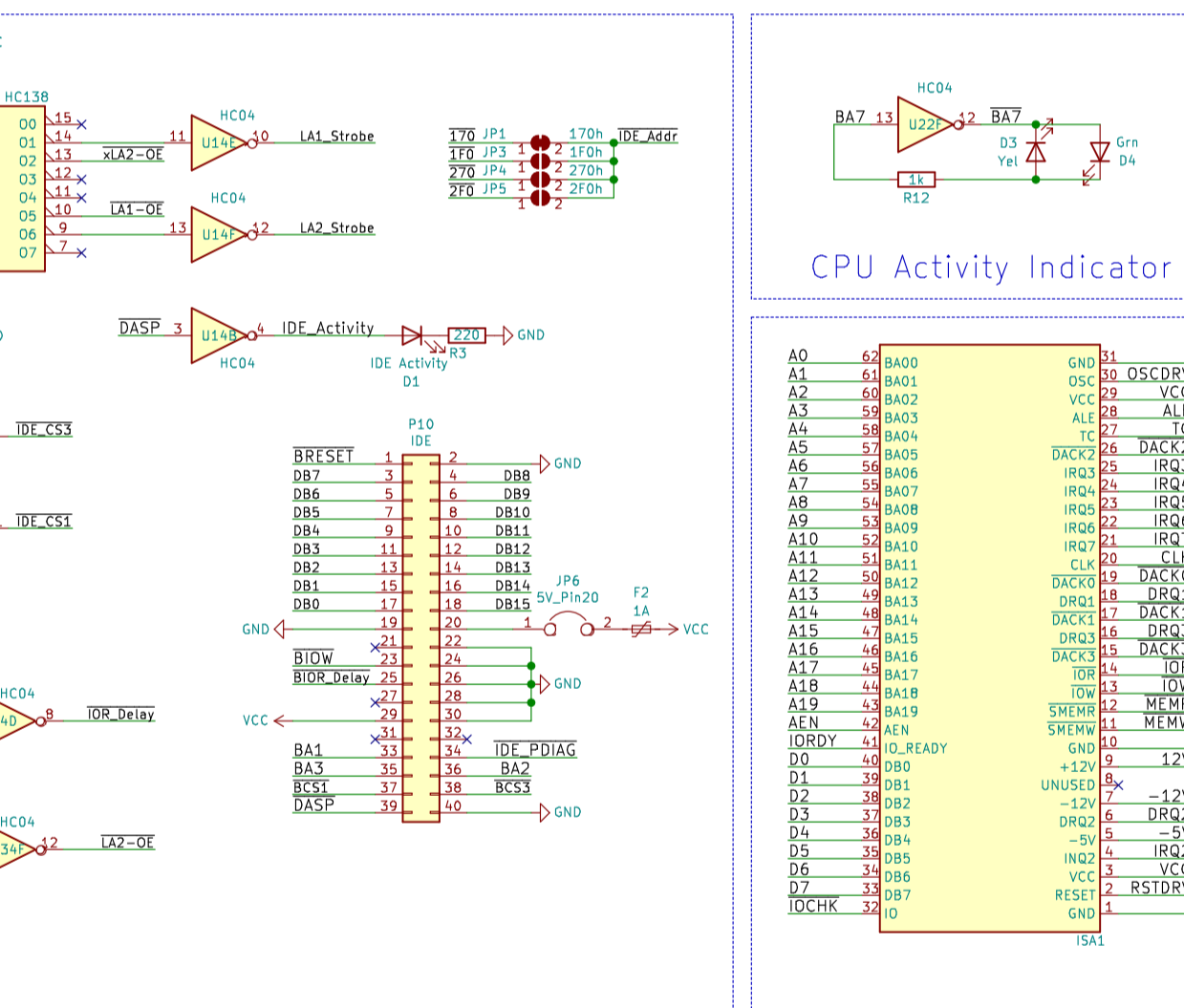

Multi-unit Part Power

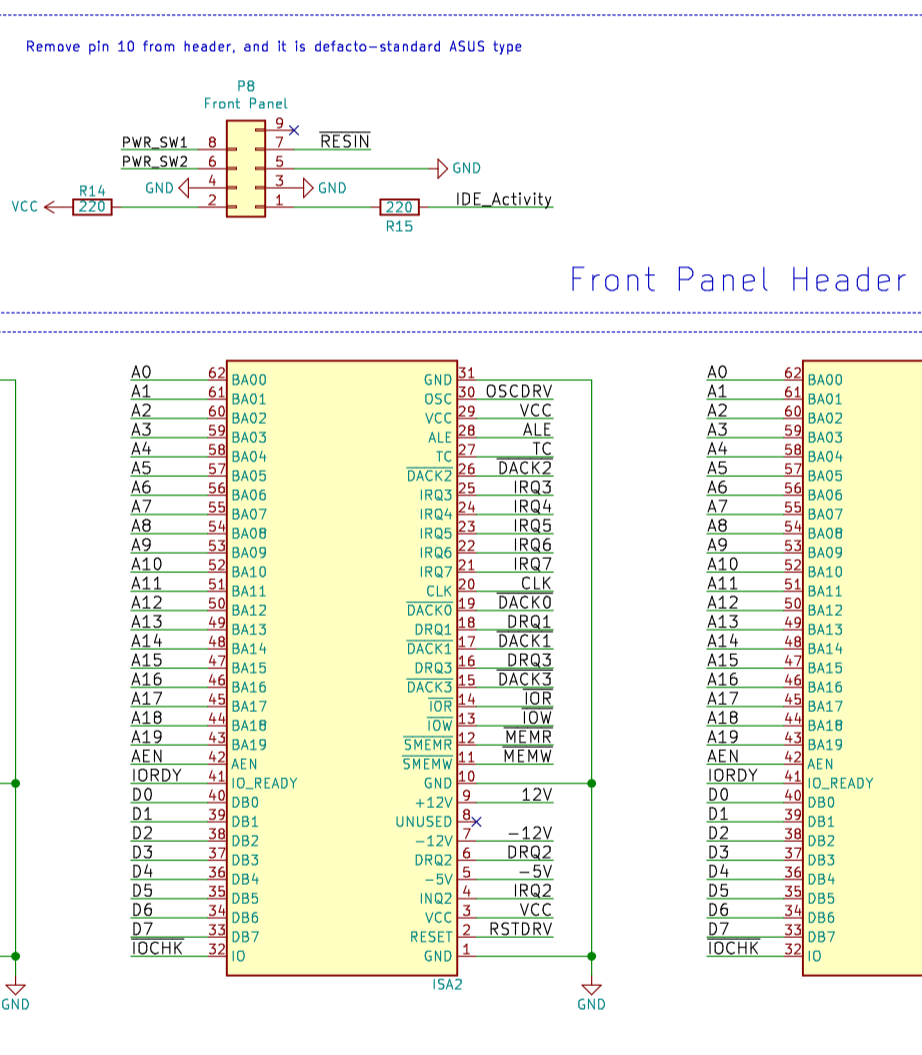

XT-IDE

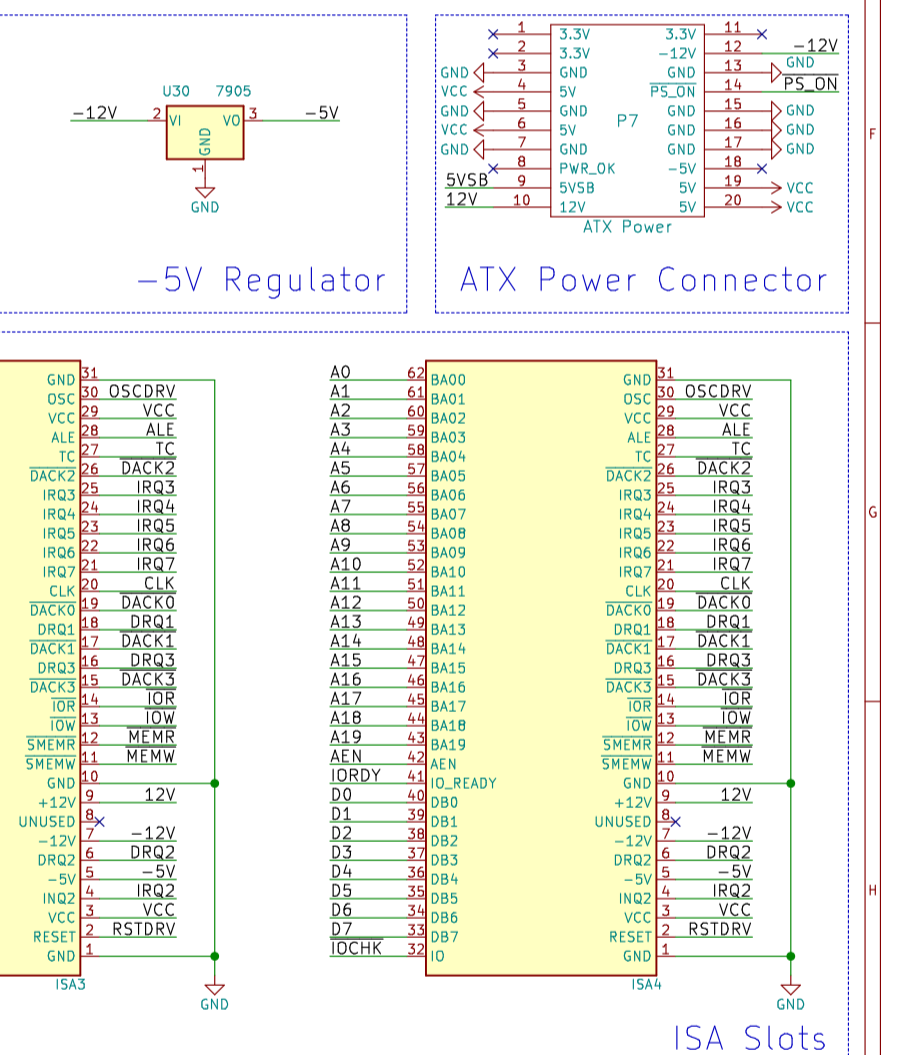

Decoupling Capacitors

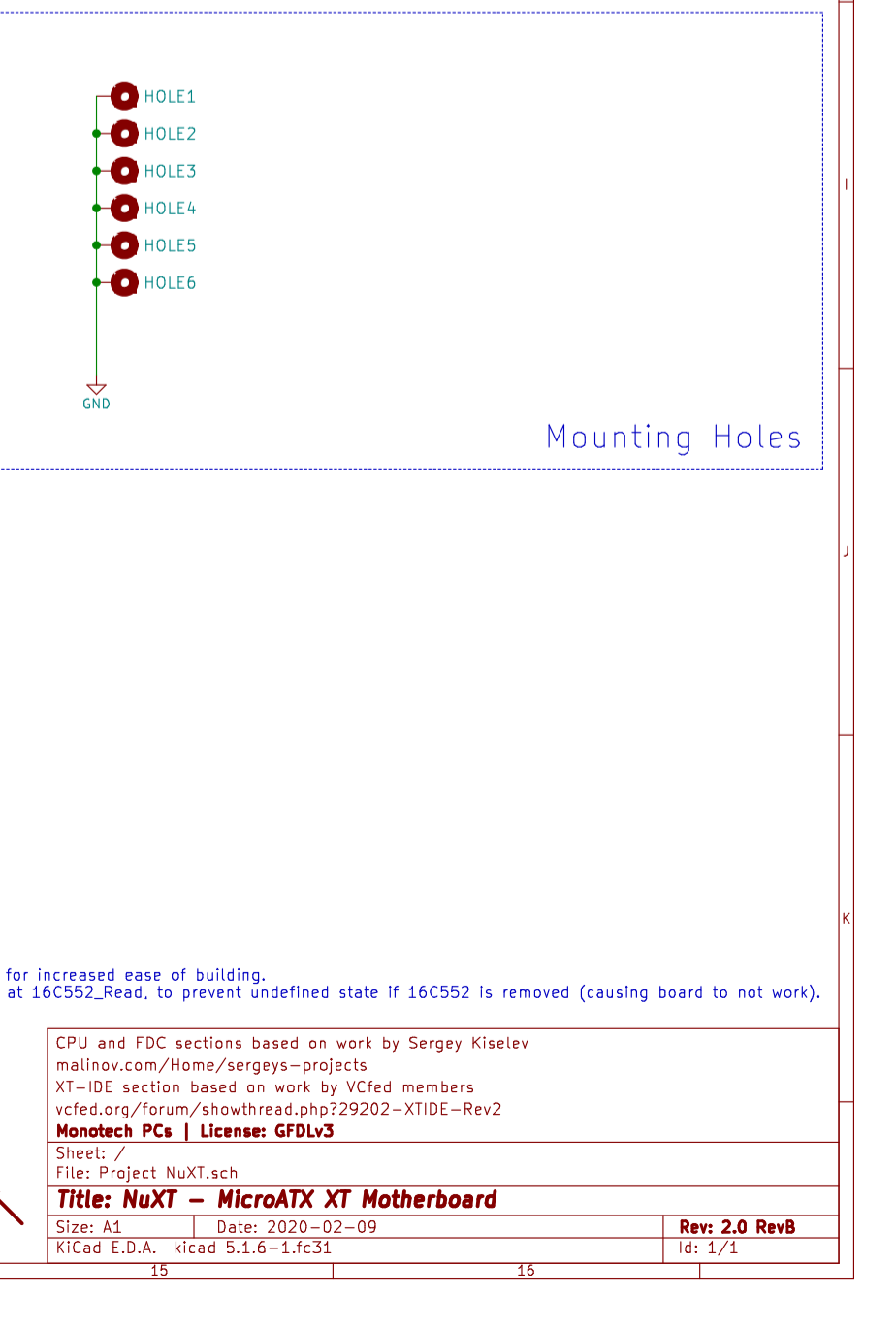

Mounting Holes

REV B changes:
- Added pull-down resistor at 16C552_Read, to prevent undefined state if 16C552 is removed (causing board to not work).

Copyright and license information for the PCB design, including project name and version.

It's feature-creepy!